

Throttles type ED

Restrictor check valves type RD and RDF/..

Operating pressure p_{max} = 500 bar
 Flow Q_{max} = 130 lpm

1. General

Throttle valves belong to the flow valve group (ISO 1219-1). They are used in hydraulic systems as resistance valves. This effect is based on the intentional utilization of the variable Δp -Q-characteristic.

The flow resistance can be regulated very precisely with both the manually and the tool adjustable version. Size 11 and 21 of type ED (RD) are basically designed as slot-type throttles, where the cross section is extended by an annular gap only for the last quarter of the stroke i.e. in the range of the greatest opening. Size 31 to 51 of type ED (RD) are pure annular gap throttles. The non-adjustable version RDF.. is a orifice type throttle. The check valve is designed as a tilt plate with a low mass, a spring is omitted (no malfunction due to a broken). The valve opens and closes with the slightest fluid flow. The adjustment spindle is nitrided (making it wear resistant) and is permanently lubed by the hydraulic fluid (maintenance free).

Type ED.. and ED..K

Throttle

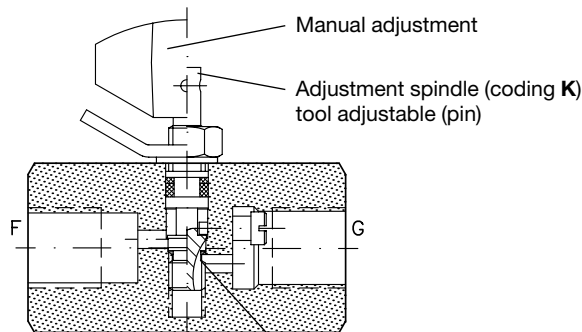
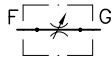

Annular throttling area, between the edge of the bore and the taper (hardened)

Type RD.. and RD..K

Restrictor check valve

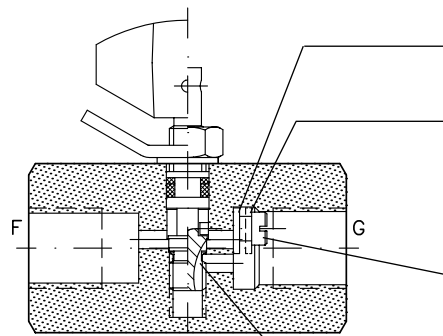
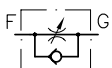

Check valve disc:
closed position (flow via throttle)

Open position (free flow)

Fixture screw for check valve, acting additionally as stop for the spindle (prevents the spindle to be screwed out too far)

Annular throttling area, between the edge of the bore and the taper (hardened)

Type RDF..

Restrictor check valve with fine throttle

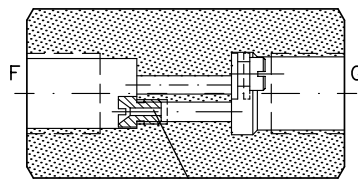
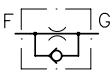

RDF 11: Orifice M4x0.6 ... 1.8

RDF 21: Orifice M5x0.6 ... 2.0

Orifice secured by liquid screw lock

RDF 31 to 51: Orifice disc $\varnothing 1.0$... 4.5 with fixture screw

2. Available versions, main data

Order examples:

RD 11 Throttle (manually adjustable)

ED 31 **K** Throttle (tool adjustable)

RDF 21/1,0 Restrictor check valve

Adjustability (only type ED.. and RD.. !)

no coding = manually adjustable (wing screw / lock nut)

K = tool adjustable (adjustment spindle / lock nut)

Table 2: Fixed throttle RDF ../..

∅ (mm)	0.4	0.5	0.6	0.8	1.0	1.2	1.4	1.6	1.8	2.0	2.5	3.0	3.5	4.0	4.5	5.0	5.5
Coding	0,4	0,5	0,6	0,8	1,0	1,2	1,4	1,6	1,8	2,0	2,5	3,0	3,5	4,0	4,5	5,0	5,5
RDF 11/..	•	•	•	•	•	•	•	•	•								
	Orifice M 4 x ...																
RDF 21/..		•	•	•	•	•	•	•	•	•							
	Orifice M 5 x ...																
RDF 31/..				•	•	•	•	•	•	•	•	•	•	•	•	•	•
RDF 41/..				•	•	•	•	•	•	•	•	•	•	•	•	•	•
RDF 51/..				•	•	•	•	•	•	•	•	•	•	•	•	•	•
	Orifice disc with fixture screw																

Table 1: Basic type, size

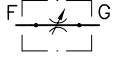
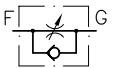
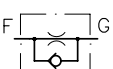
Version	Coding	Ports F and G conf. ISO 228/1 (BSPP)	Pressure p_{max} (bar)	Flow Q_{max} (lpm)	Mass (weight) approx. (g)
Throttle 	ED 11	G 1/4	500	12	180
	ED 21	G 3/8		30	220
	ED 31	G 1/2		60	350
	ED 41	G 3/4		80	660
	ED 51	G 1		130	840
Restrictor check valve  with fixed throttle F → G free flow F ← G throttled flow 	RD 11, RD 112	G 1/4	500	12	180
	RD 21	G 3/8		30	220
	RD 31	G 1/2		60	350
	RD 41	G 3/4		80	660
	RD 51	G 1		130	840
	RDF 11/..	G 1/4	500	12	180
	RDF 21/..	G 3/8		30	220
	RDF 31/..	G 1/2		60	350
	RDF 41/..	G 3/4		80	660
	RDF 51/..	G 1		130	840

Note: The throttle characteristic of type RD 112 is more fine than with type RD 11, see curves in sect. 3

3. Additional parameters

Installed position	Any
Hydraulic fluid:	Hydraulic oil conforming DIN 51524 table 1 to 3 (ISO VG 10 to 68 conf. DIN 51 519) Viscosity range: min. approx. 4; max. approx. 1500 mm ² /s Optimum: 10 to 500 mm ² /s Also suitable are biologically degradable pressure fluids type HEPG (Polyalkylenglykol) and HEES (synth. Ester) at operation temperatures up to approx. +70°C.
Temperature	Ambient: approx. -40...+80°C Fluid: -25...+80°C, pay attention to the viscosity range! Start temperature down to -40°C are allowable (Pay attention to the viscosity range during start!), as long as the operation temperature during subsequent running is at least 20K higher. Biological degradable pressure fluids: Pay attention to manufacturer's information. With regard to the compatibility with sealing materials do not exceed +70°C.
Δp-Q curves	Throttling direction G → F with type ED..(K) and RD..(K)

Type ED 11, RD 11

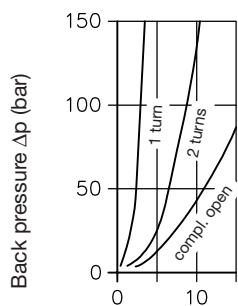

Type RD 112

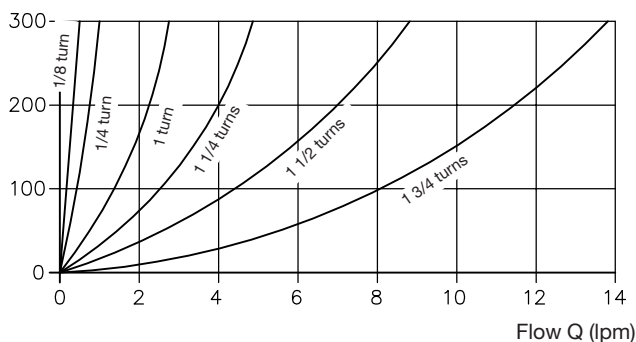

Type ED 21, RD 21

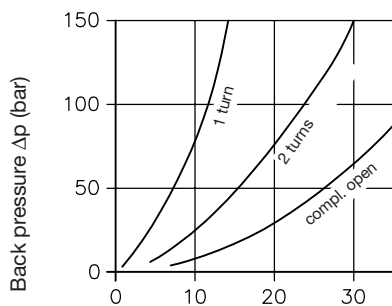

Type RD 31... (41, 51) and ED 31... (41, 51)

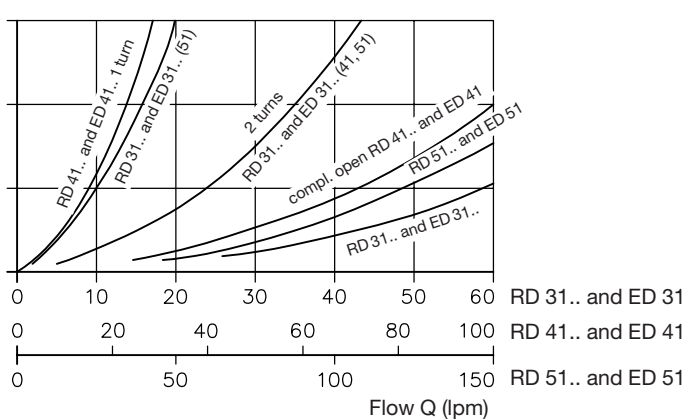

Throttling direction G → F with type RDF..

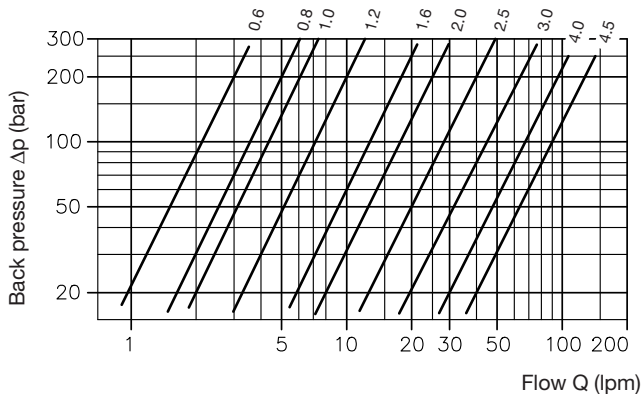

Free flow F → G with type RD(F) 11 to RD(F) 51

Δp ≈ 3 bar at approx. 0.5 Q_{max}
Δp ≈ 8 bar at approx. Q_{max}
For Q_{max} see main data in table 1, sect. 2

Oil viscosity during measuring approx. 54 mm²/s

Attention: The throttles show a certain viscosity dependence, the Δp-Q curves can differ more or less strongly when used beyond the optimal range.

4. Unit dimensions

Type ED.. and RD..

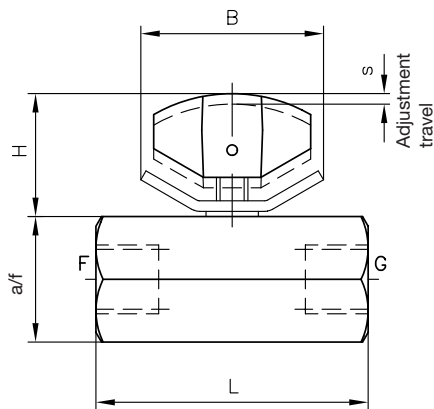
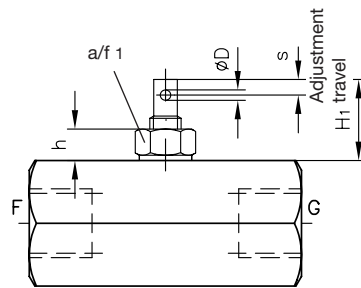
Type ED..K
RD..K

Type RDF ../..



Type	Ports F and G ISO 228/1 (BSPP)	L	H	H ₁	h	D	B	a/f	a/f ₁	Adjustment travel s approx.	Turns approx.
ED 11(K), RD 11(K), RDF 11/..	G 1/4	52	23.5	15.5	6	2	32	24	10	2.25	2 1/4
ED 21(K), RD 21(K), RDF 21/..	G 3/8		24	16.5				27		2.5	
ED 31(K), RD 31(K), RDF 31/..	G 1/2	62	32.5	21.5	7.5	3	45	32	13	3	3
ED 41(K), RD 41(K), RDF 41/..	G 3/4	72	41	25.5		3.5	55.5	41	17	4.5	
ED 51(K), RD 51(K), RDF 51/..	G 1	82	46.5	26.5		4	61	46	19	4.5	

All dimensions in mm, subject to change without notice!