



## 2H Hydraulic Cylinders

Heavy Duty NFPA Tie Rod Cylinders for  
Working Pressures up to 210 bar

aerospace  
climate control  
electromechanical  
filtration  
fluid & gas handling  
**hydraulics**  
pneumatics  
process control  
sealing & shielding



ENGINEERING YOUR SUCCESS.

**2H Cylinder Mounting Styles**

The standard range of Parker 2H cylinders comprises 17 mounting styles. Dimensional information for each mounting style is shown on pages 10-21 for 38.1mm to 203.2mm (1½" to 8") bore sizes, and on pages 22-25 for 254mm and 304.8mm (10" and 12") bore sizes.

Application-specific mounting information is shown on page 31. Where a non-standard mounting style is required, please contact the factory for details.

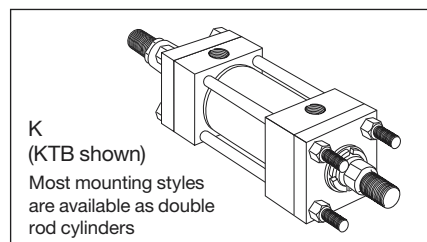
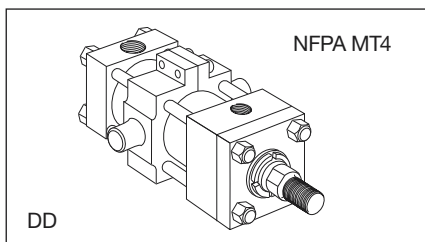
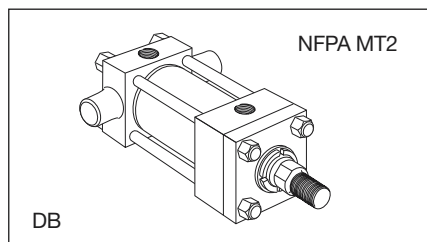
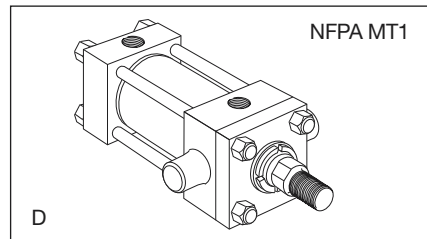
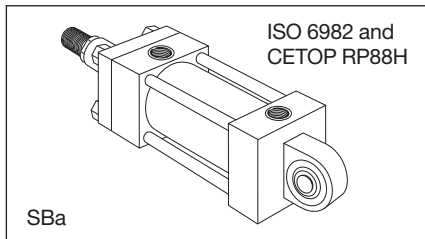
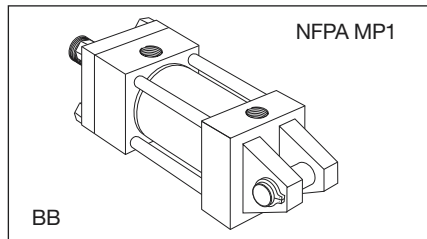
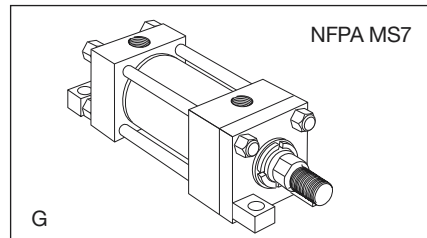
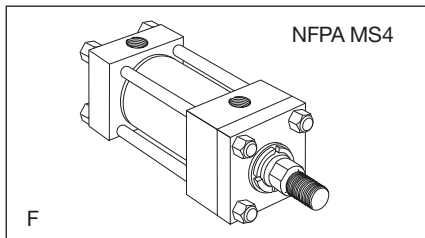
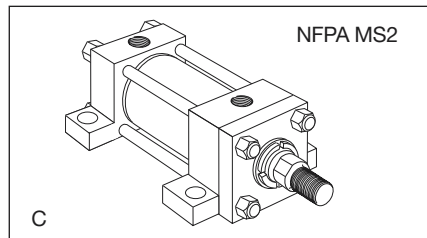
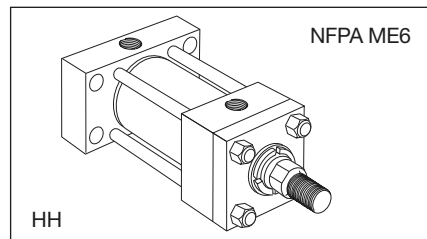
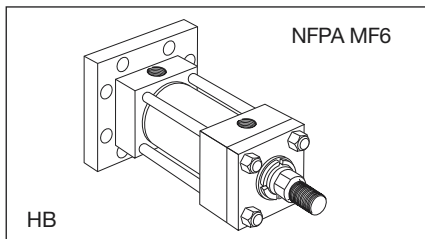
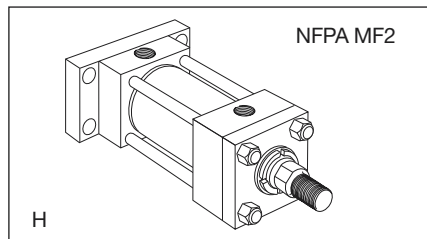
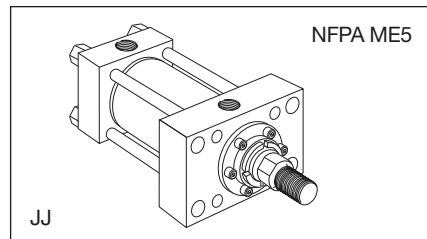
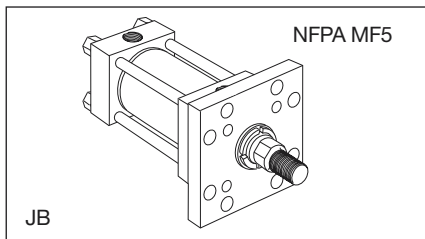
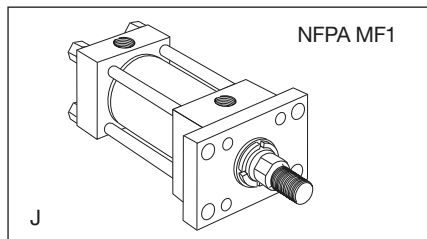
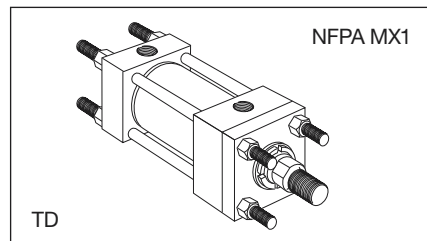
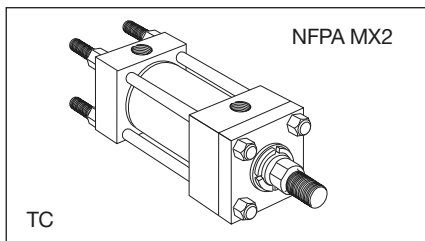
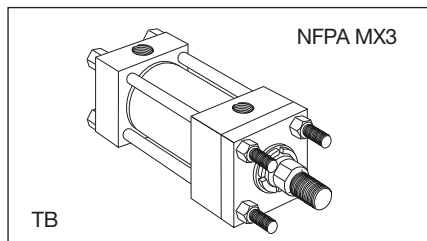

**38.1mm to 203.2mm (1½" to 8") Bores Only**

**Rod End Styles 4, 7 & 8**  
**- All Except JJ Mount**

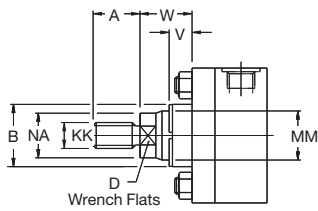

**Rod End Style 9**  
**- All Except JJ Mount**

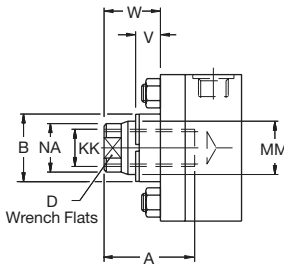

**Rod End Styles 4, 7 & 8**  
**- JJ Mount Only**

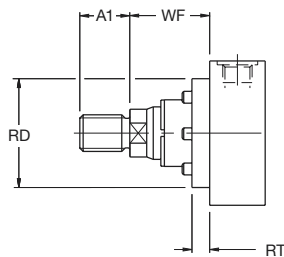

**Rod End Style 9**  
**- JJ Mount Only**

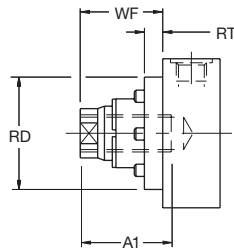

**Rod End Styles 4 & 8**

The standard rod end, Style 4, is recommended for all applications in which the work piece is secured against the rod shoulder. Where the work piece is not shouldered, Style 8 rod ends are recommended.

**Rod End Style 9**

For applications where a female thread is required.

**Rod End Style 3**

Non-standard piston rod ends are designated 'Style 3'. A dimensional sketch or description should accompany the order. Please specify dimensions KK and A.

**Rod End Style 7**

Style 7 rod ends apply to rod eyes with spherical bearings only (see pages 27 and 29). The Style 7 rod end with spherical bearing allows the same diameter pivot pin to be used at both the head and cap ends of the cylinder. For Style 7 rod end thread lengths, please refer to dimension A1 in the table below.

**Style JJ**

Dimensions which are not shown are identical to those shown for the equivalent non-JJ design.

**Rod End Dimensions – 38.1mm to 203.2mm (1½" to 8") bore sizes only**

Bore Ø	Rod No.	MM Rod Diameter	Style 4 & 9		Style 8		Style 7 <sup>2</sup>		A	B <sup>+0.00 -0.05</sup>	D	NA	V	W	JJ Mount Only		
			KK Metric	KK UNF <sup>1</sup>	KK Metric	KK UNF	KK Metric	A1							RD max.	RT	WF
38.1 (1½")	1	15.9 (5/8")	M10x1.5	7/16 - 20	M12x1.5	1/2 - 20	-	21	19.0	28.55	13	14.3	6.4	15.9	54.0	9.5	25.4
	2	25.4 (1")	M20x1.5	3/4 - 16	M22x1.5	7/8 - 14	M16x1.5	27	28.6	38.07	22	23.8	12.7	25.4	63.5	9.5	35.0
50.8 (2")	1	25.4 (1")	M20x1.5	3/4 - 16	M22x1.5	7/8 - 14	M20x1.5	27	28.6	38.07	22	23.8	6.4	19.1	63.5	9.5	35.0
	2	34.9 (1 3/8")	M26x1.5	1 - 14	M30x2	1 1/4 - 12	M20x1.5	27	41.3	50.77	30	33.3	9.5	25.4	76.2	9.5	41.3
63.5 (2½")	1	25.4 (1")	M20x1.5	3/4 - 16	M22x1.5	7/8 - 14	-	35	28.6	38.07	22	23.8	6.4	19.1	63.5	9.5	35.0
	2	44.5 (1 3/4")	M33x2	1 1/4 - 12	M39x2	1 1/2 - 12	M27x2	35	50.8	60.30	36	42.9	12.7	31.8	88.9	9.5	47.7
	3	34.9 (1 3/8")	M26x1.5	1 - 14	M30x2	1 1/4 - 12	M27x2	35	41.3	50.77	30	33.3	9.5	25.4	76.2	9.5	41.3
82.6 (3 1/4")	1	34.9 (1 3/8")	M26x1.5	1 - 14	M30x2	1 1/4 - 12	-	44	41.3	50.77	30	33.3	6.4	22.2	76.2	9.5	41.3
	2	50.8 (2")	M39x2	1 1/2 - 12	M45x2	1 3/4 - 12	M33x2	44	57.1	66.65	41	49.2	9.5	31.8	101.6	15.9	50.8
	3	44.5 (1 3/4")	M33x2	1 1/4 - 12	M39x2	1 1/2 - 12	M33x2	44	50.8	60.30	36	42.9	9.5	28.6	88.9	9.5	47.7
101.6 (4")	1	44.5 (1 3/4")	M33x2	1 1/4 - 12	M39x2	1 1/2 - 12	-	55	50.8	60.30	36	42.9	6.4	25.4	88.9	9.5	47.7
	2	63.5 (2 1/2")	M48x2	1 7/8 - 12	M56x2	2 1/4 - 12	M42x2	55	76.2	79.35	55	60.3	9.5	34.9	114.3	15.9	57.2
	3	50.8 (2")	M39x2	1 1/2 - 12	M45x2	1 3/4 - 12	M42x2	55	57.1	66.65	41	49.2	6.4	28.6	101.6	15.9	50.8
127.0 (5")	1	50.8 (2")	M39x2	1 1/2 - 12	M45x2	1 3/4 - 12	-	62	57.1	66.65	41	49.2	6.4	28.6	101.6	15.9	50.8
	2	88.9 (3 1/2")	M64x2	2 1/2 - 12	M76x2	3 1/4 - 12	M48x2	62	88.9	107.92	75	85.7	9.5	34.9	146.1	15.9	57.2
	3	63.5 (2 1/2")	M48x2	1 7/8 - 12	M56x2	2 1/4 - 12	M48x2	62	76.2	79.35	55	60.3	9.5	34.9	114.3	15.9	57.2
	4	76.2 (3")	M58x2	2 1/4 - 12	M68x2	2 3/4 - 12	-	62	88.9	95.22	65	73.0	9.5	34.9	133.4	15.9	57.2
152.4 (6")	1	63.5 (2 1/2")	M48x2	1 7/8 - 12	M56x2	2 1/4 - 12	-	84	76.2	79.35	55	60.3	6.4	31.8	114.3	15.9	57.2
	2	101.6 (4")	M76x2	3 - 12	M95x2	3 3/4 - 12	M64x3	84	101.6	120.62	85	98.4	6.4	31.8	165.1	19.1	57.2
	3	76.2 (3")	M58x2	2 1/4 - 12	M68x2	2 3/4 - 12	-	84	88.9	95.22	65	73.0	6.4	31.8	133.4	15.9	57.2
	4	88.9 (3 1/2")	M64x2	2 1/2 - 12	M76x2	3 1/4 - 12	M64x3	84	88.9	107.92	75	85.7	6.4	31.8	146.1	15.9	57.2
177.8 (7")	1	76.2 (3")	M58x2	2 1/4 - 12	M68x2	2 3/4 - 12	-	-	88.9	95.22	65	73.0	6.4	31.8	133.4	15.9	57.2
	2	127.0 (5")	M90x2	3 1/2 - 12	M110x2	4 3/4 - 12	-	-	127.0	146.02	110	123.8	6.4	31.8	190.5	25.4	57.2
	3	88.9 (3 1/2")	M64x2	2 1/2 - 12	M76x2	3 1/4 - 12	-	-	88.9	107.92	75	85.7	6.4	31.8	146.1	15.9	57.2
	4	101.6 (4")	M76x2	3 - 12	M95x2	3 3/4 - 12	-	-	101.6	120.62	85	98.4	6.4	31.8	165.1	19.1	57.2
203.2 (8")	1	88.9 (3 1/2")	M64x2	2 1/2 - 12	M76x2	3 1/4 - 12	-	-	88.9	107.92	75	85.7	6.4	31.8	146.1	15.9	57.2
	2	139.7 (5 1/2")	M100x2	4 - 12	M130x2	5 1/4 - 12	-	-	139.7	158.72	120	136.5	6.4	31.8	209.6	19.1	57.2
	3	101.6 (4")	M76x2	3 - 12	M95x2	3 3/4 - 12	-	-	101.6	120.62	85	98.4	6.4	31.8	165.1	19.1	57.2
	4	127.0 (5")	M90x2	3 1/2 - 12	M110x2	4 3/4 - 12	-	-	127.0	146.02	110	123.8	6.4	31.8	190.5	25.4	57.2

<sup>1</sup> All rod threads are UNF except 1" - 14 which is UNS.

<sup>2</sup> Style 7 threads apply to spherical rod eyes only, see pages 27 and 29.

All dimensions are in millimetres unless otherwise stated.

**Storage**

When cylinders must be stored for a period of time, the following procedures are recommended:

1. Store the cylinders in an indoor area which has a dry, clean and non-corrosive atmosphere. Take care to protect the cylinder from both internal corrosion and external damage.
2. Whenever possible, cylinders should be stored in a vertical position (piston rod up). This will minimize corrosion due to possible condensation which could occur inside the cylinder.
3. Port protector plugs should be left in the cylinder until the time of installation.

**Installation**

1. Cleanliness is an important consideration, and Parker cylinders are shipped with the ports plugged to protect them from contaminants entering the ports. These plugs should not be removed until the piping is to be installed. Before making the connection to the cylinder ports, piping should be thoroughly cleaned to remove all debris which might have resulted from threading or flaring operations.
2. Cylinders operating in an environment where air drying materials are present such as fast-drying chemicals, paint, or weld splatter, or other hazardous conditions such as excessive heat, should have shields installed to prevent damage to the piston rod and piston rod seals.
3. Correct alignment of the cylinder piston rod and its mating component on the machine should be checked in both the extended and retracted positions. Incorrect alignment will result in excessive rod gland and/or cylinder bore wear, shortening the life of the cylinder.

**Masses – Series 2H Cylinders**

To determine the mass of the cylinder, first select the basic mass for zero stroke, then calculate and add the mass for the appropriate stroke length. Masses for accessories are shown on pages 27 to 29.

Bore Ø	Rod No.	Single Rod Cylinders			Double Rod Cylinders		
		Mass at Zero Stroke		Mass per 10mm Stroke kg	Mass at Zero Stroke		Mass per 10mm Stroke kg
		Mounting Styles			Mounting Styles		
		TB, TC, TD, J, JB, H, HB, F kg	JJ, HH, D, DB, DD, C, G, SBa, BB kg		TB, TD, J, JB, F kg	JJ, C, G, D, DD kg	
38.1 (1½")	1	3.6	4.7	0.09	4.1	5.23	0.10
	2	3.7	4.9	0.11	4.4	5.53	0.15
50.8 (2")	1	5.7	7.5	0.14	6.9	8.74	0.18
	2	6.0	7.8	0.18	7.5	9.34	0.25
63.5 (2½")	1	7.9	10.1	0.19	9.4	11.7	0.23
	2	8.7	11.0	0.27	11.0	13.3	0.39
	3	8.2	10.8	0.22	10.0	12.7	0.30
82.6 (3¼")	1	15.2	19.4	0.31	18.2	22.5	0.39
	2	16.1	20.4	0.39	20.0	24.3	0.55
	3	15.7	19.9	0.36	19.2	23.5	0.48
101.6 (4")	1	20.4	25.7	0.39	25	31	0.51
	2	22.2	27.5	0.51	29	35	0.76
	3	20.8	26	0.42	26	32	0.58
127.0 (5")	1	36	44	0.59	43	52	0.75
	2	41	49	0.92	53	62	1.40
	3	37	46	0.68	46	55	0.93
	4	39	47	0.79	49	58	1.20
152.4 (6")	1	58	71	0.92	68	82	1.2
	2	64	77	1.3	80	94	2.0
	3	60	73	1.1	71	85	1.4
	4	62	75	1.2	74	88	1.7
177.8 (7")	1	86	105	1.2	99	119	1.5
	2	97	116	1.8	122	142	2.8
	3	88	107	1.3	103	123	1.8
	4	90	109	1.4	108	128	2.1
203.2 (8")	1	120	145	1.6	137	163	2.1
	2	135	160	2.3	166	192	3.5
	3	123	148	1.8	142	168	2.4
	5	130	155	2.1	157	183	3.1
254.0 (10")	1	275	328	3.0	325	378	4.0
	2	291	344	4.0	357	410	5.9
304.8 (12")	1	444	527	3.9	519	603	5.1
	2	474	557	5.6	579	663	8.4

**Warning**

FAILURE OR IMPROPER SELECTION OR IMPROPER USE OF THE PRODUCTS AND/OR SYSTEMS DESCRIBED HEREIN OR RELATED ITEMS CAN CAUSE DEATH, PERSONAL INJURY AND PROPERTY DAMAGE.

This document and other information from Parker Hannifin Corporation, its subsidiaries, sales offices and authorized distributors provide product or system options for further investigation by users having technical expertise. Before you select or use any product or system it is important that you analyse all aspects of your application and review the information concerning the product or system in the current product catalogue. Due to the variety of operating conditions and applications for these products or systems, the user, through his own analysis and testing, is solely responsible for making the final selection of the products and systems and assuring that all performance and safety requirements of the application are met.

The products described herein, including without limitation, product features, specifications, designs, availability and pricing, are subject to change by Parker Hannifin Corporation and its subsidiaries at any time without notice.

**Offer of Sale**

Please contact your local Parker representative for a detailed offer of sale.

All dimensions are in millimetres unless otherwise stated.



**Parker Offers the Widest Range of Industrial Cylinders**

**High Productivity – Low Cost of Ownership**

Parker Hannifin’s Cylinder Division is the world’s largest supplier of hydraulic cylinders for industrial applications.

Parker manufactures a vast range of standard and special tie rod, roundline and ‘mill’ type cylinders to suit all types of industrial cylinder applications. Our cylinders are available to ISO, DIN, NFPA, ANSI and JIC standards, with other certifications available on request. All Parker hydraulic cylinders are designed to deliver long, efficient service with low maintenance requirements, guaranteeing high productivity year after year.

**About Parker Hannifin**

Parker Hannifin is the global leader in motion and control technologies, partnering with its customers to increase their productivity and profitability. The company employs more than 52,000 people in 48 countries around the world, providing customers with technical excellence and first class customer service.

Visit us at [www.parker.com](http://www.parker.com)



**Standard Specifications**

- Heavy-duty service – ANSI B93.15-1987 and NFPA specifications
- Standard construction – square end, tie rod design
- Standard pressure – 210 bar
- Standard fluid – hydraulic mineral oil
- Standard temperature – -20°C to 80°C (-4°F to 176°F)

**Contents**

**Page**

Piston Rod End Data – 38.1mm to 203.2mm (1½" to 8") bores	3
Storage Information & Mass Data	4
Standard Specifications	5
Design Features and Benefits	6
Cylinder Selection Check List	8
Mounting Styles	9
Double Rod Cylinders	26
Accessories	27
Mounting Information	30
Push and Pull Forces	32
Piston Rod Sizes & Stop Tubes	33
Stroke Factors & Long Stroke Cylinders	34
Cushioning	35
Pressure Limitations	36
Ports, Locations and Piston Speeds	36
Seals & Fluids	38
Optional Features	39
Replacement Parts and Service	40
Repairs	41
Piston Rod End Data – 254.0mm and 304.8mm (10" and 12") bores	42
How to Order Cylinders	43

**The 2H Cylinder Range**

The 2H cylinders described in this catalogue are heavy duty hydraulic cylinders rated for use at working pressures up to 210 bar depending on the rod end and type of service.

In addition to the standard cylinders featured in this catalogue, 2H cylinders can be designed to suit customer requirements. Our engineers will be pleased to advise on unique designs to suit specific applications.

**inPHorm and 3-D CAD**

Parker offers easy-to-use software to simplify the cylinder selection process, saving your time and ensuring the accuracy of designs and drawings. InPHorm selection software and new 3-D CAD modelling software can be downloaded from our Cylinder Division Europe website.

Please visit us at [www.parker.com](http://www.parker.com) or contact your local Sales Office for more information.

- Bore sizes – 38.1mm (1½") to 304.8mm (12")
- Piston rod diameters – 15.9mm (5/8") to 215.9mm (8½")
- Mounting styles – 17 standard styles
- Strokes – available in any practical stroke length
- Cushions – optional at either end or both ends of stroke
- Rod ends – three standard choices – specials to order

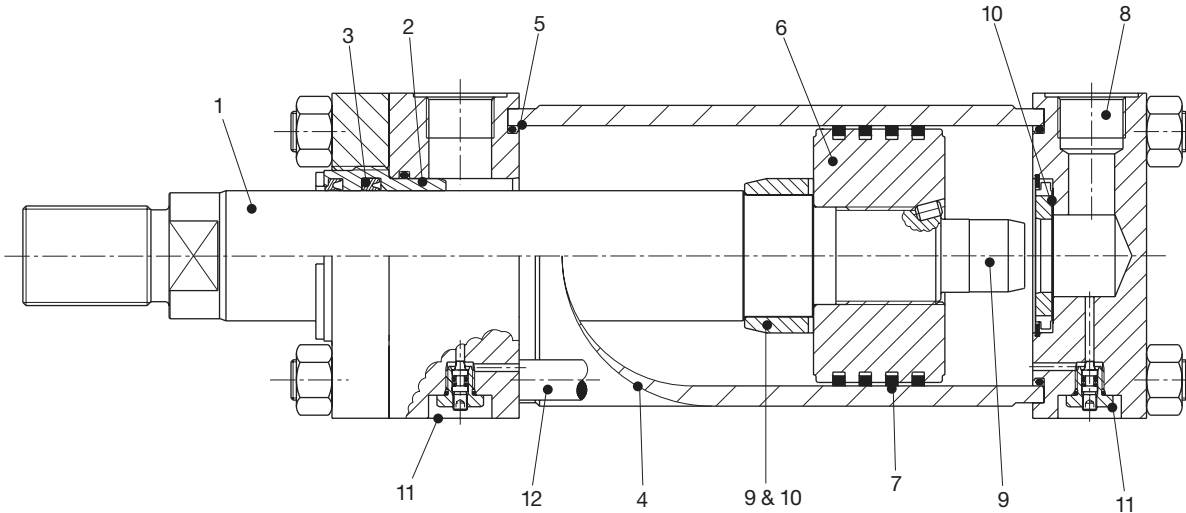

**1 Piston Rod**

Gland seal life is maximised by manufacturing piston rods from precision ground, high tensile carbon alloy steel, hard chrome plated and polished to 0.2µm max. Piston rods are induction case hardened to Rockwell C54 minimum before chrome plating, resulting in a dent-resistant surface.

**2 Parker's Rod Gland**

Continuous lubrication, and therefore longer gland life, are provided by the long bearing surface inboard of the lipseal. The gland, complete with rod seals, can easily be removed without dismantling the cylinder, so servicing is quicker – and therefore more economical.

**3 Rod Seals**

The serrated lipseal has a series of sealing edges which take over successively as pressure increases, providing efficient sealing under all operating conditions. On the return stroke the serrations act as a check valve, allowing the oil adhering to the rod to pass back into the cylinder.

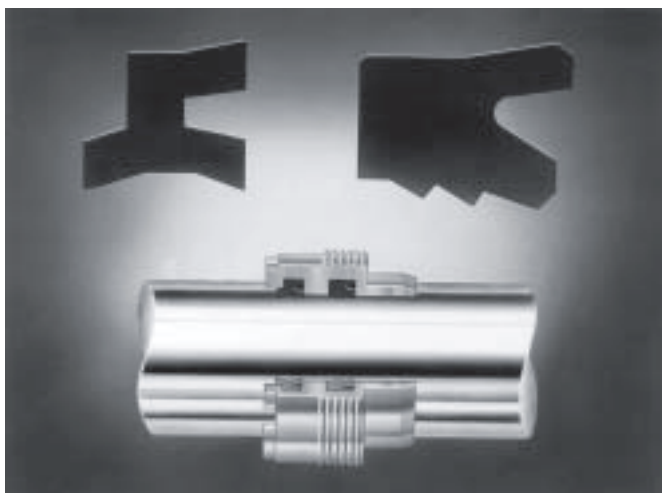

The double lip wiperseal acts as a secondary seal, trapping excess lubricating film in the chamber between the wiper and lip seals and preventing the ingress of dirt into the cylinder, extending the life of gland and seals. Standard lipseals are manufactured from an enhanced polyurethane, giving efficient retention of

fluid and a life of up to five times that of traditional seal materials. Standard rod seals are suitable for speeds up to 0.5m/s – special seal combinations are available for higher speed applications.

**4 Cylinder Body**

Strict quality control standards and precision manufacture ensure that all tubes meet rigid standards of straightness, roundness and surface finish. The steel tubing is surface finished to minimise internal friction and prolong seal life.

**5 Cylinder Body Seals**

To ensure that the cylinder body remains leak free, even under pressure shock conditions, Parker fits pressure-energised body seals.

**6 Piston**

All pistons are of one-piece type, and feature wide bearing surfaces to resist side loading. Long thread engagement secures the piston to the piston rod and, for additional safety, the piston is secured by thread-locking adhesive and a locking pin.

**7 Piston Seals**

**Cast Iron Piston Rings** are extremely durable but allow some leakage across the piston and cannot therefore hold a load in position. Cast iron piston rings are fitted as standard on series 2H hydraulic cylinders.

**Lipseal Pistons** can hold a load in position, but are not as durable as pistons with cast iron rings or Hi-Load seals. For applications with a working pressure in excess of 140 bar where the duty cycle requires sustained piston speeds in excess of 0.4m/s or high cycling performance, other seal options should also be considered. Where these performance criteria may be exceeded, please contact the factory with details of the application.

**Hi-Load Pistons** resist side loading and are recommended for long stroke cylinders, especially when pivot mounted. Special wear rings prevent metal-to-metal contact between the piston and tube and thereby extend the life of the cylinder.

**Low Friction Seals** are also available – see page 37.

## 8 Ports

High piston speeds allow rapid cycling, which maximises machine productivity. Parker offers a range of port sizes to permit different flow rates, in all common inch and metric standards. Choosing the correct port size simplifies design and installation, and cuts maintenance time to a minimum.

## 9 Cushioning

Progressive deceleration reduces both noise and shock, prolonging machine life and improving the working environment. Parker 2H cylinders are available with stepped cushions at the head and cap, which decelerate a load safely while optimising the cycling rate of the process. The head and cap end cushions are self centring. The polished cap end spear is an integral part of the piston rod.

## 10 Floating Cushion Bushes & Sleeves

Closer tolerances – and therefore more effective cushioning – are permitted by the use of a floating cushion sleeve at the head end of the cylinder, and a floating cushion bush at the cap end. A specially designed cushion sleeve on bore sizes up to 101.6mm (4") operates as a check valve. On larger bore sizes a conventional ball check valve is used. The use of a check valve in the head and lifting of the bronze cushion bush in the cap, provides minimum fluid flow restriction at the start of the return stroke. This allows full pressure to be applied over the whole area of the piston, to provide full power and fast cycle times.

## 11 Cushion Adjustment

Needle valves are provided at both ends of the cylinder for precise cushion adjustment, and retained within the head and cap so that they cannot be inadvertently removed. The cartridge type needle valve illustrated is fitted to cylinders of up to 63.5mm (2½") bore. See page 35 for location.

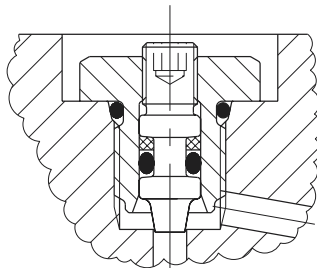

## 12 Tie Rod Construction

Tie rod construction, with tie rods torque-loaded on assembly, imposes a compressive force on the cylinder tube which counters the tensile forces generated by system pressure. The result – a fatigue-free cylinder with long service life and exceptionally compact dimensions.

## Seal Classes

To accommodate the many types of fluid and the varying temperature ranges used in industry, Parker offers a range of rod gland, piston and body seals moulded in different profiles and from different materials. These are described in detail on page 37.

## Special Designs

Parker's design and engineering staff are available to produce special designs to meet customer's specific requirements. Alternative sealing arrangements, special mounting styles, different bores and rod sizes are just a few of the custom features which can be supplied.

**Air Bleeds**

The option of air bleeds is available at either or both ends of the cylinder, at any position except in the port face – see page 35 for location. To ensure operator safety, the standard M8 air bleed screw (illustrated) is recessed into the head and cap and retained so that it cannot be inadvertently removed.

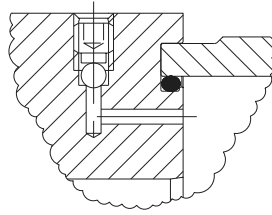

**Gland Drains**

The accumulation of fluid between the gland seals of long stroke cylinders, cylinders with constant back pressure or where the ratio of the extend speed to the retract speed is greater than 2 to 1, can be relieved by specifying an optional gland drain. A transparent tube fitted between the gland drain and the reservoir allows fluid loss from concealed or inaccessible cylinders to be monitored, giving an early indication of the need for gland servicing.

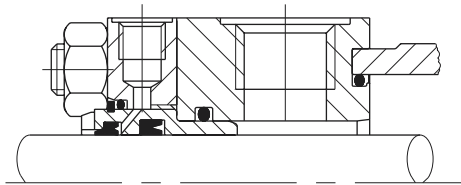

A 1/8" NPTF gland drain port can be provided in the retainer on all cylinders up to and including 203.2mm (8") bore sizes, except 38.1mm (1 1/2") with no. 1 rod. For 38.1mm (1 1/2") bore cylinders with no.2 rod, the retainer thickness is increased to 15.9mm (5/8"). For 38.1mm (1 1/2") bore cylinders with no.1 rod, the drain port is located in the head end adjacent to the port.

**Stroke Limiters**

Where absolute precision in stroke length is required, a screwed adjustable stop can be supplied at the cap end. Several types are available – the illustration shows a design suitable for infrequent adjustment of an uncushioned cylinder. Please contact the factory, specifying details of the application and the adjustment required.

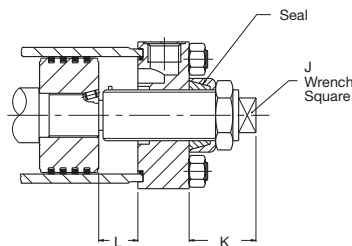

Bore Ø	J	K min.	L max.
38.1 (1 1/2")	11	55	127.0
50.8 (2")	17	75	203.2
63.5 (2 1/2")	17	75	228.6
82.6 (3 1/4")	22	85	228.6
101.6 (4")	24	70	457.2
127.0 (5")	32	70	508.0
152.4 (6")	41	75	508.0
177.8 (7")	50	75	508.0
203.2 (8")	60	80	508.0

**Rod Locking Devices**

These units provide positive locking of the piston rod. They require hydraulic pressure to release, while loss of pressure causes the clamp to operate, allowing them to be used as a fail-safe device. Please consult the factory for further information.

**Single-Acting Cylinders**

Standard 2H series cylinders are of the double-acting type. They are also suitable for use as single-acting cylinders, where the load or other external force is used to return the piston after the pressure stroke. Cast iron piston rings should not be used with single-acting cylinders.

**Spring-Returned, Single-Acting Cylinders**

Single-acting cylinders can be supplied with an internal spring to return the piston after the pressure stroke. Please supply details of load conditions and friction factors, and advise whether the spring is required to advance or return the piston rod.

On spring-returned cylinders, it is recommended that tie rod extensions be specified to allow the spring to be 'backed off' until compression is relieved. Please consult the factory when ordering spring-returned cylinders.

**Multiple Stroke Positioning**

To obtain linear force in one plane with controlled stopping at intermediate points, several designs are available. For three stopped positions, it is common practice to mount two standard single rod Style H cylinders back-to-back, or to use through-tie rods. By extending or retracting the stroke of each cylinder independently, it is possible to achieve three positions at the piston ends. An alternative technique is to use a tandem cylinder with an independent piston rod in the cap section. Please consult the factory for further details.

**Rod End Bellows**

Unprotected piston rod surfaces which are exposed to contaminants with air hardening properties should be protected by rod end bellows. Longer rod extensions are required to accommodate the collapsed length of the bellows. Please consult the factory for further information.

**Metallic Rod Wipers**

Metallic rod wipers replace the standard wiper seal, and are recommended where dust, ice or splashing might damage the wiper seal material. They do not affect cylinder dimensions.

**DC Proximity Sensors**

These can be fitted to give precise, repeatable end of stroke signals. Please contact the factory for details.

**Position Feedback**

Linear position transducers of various types are available for 2H series cylinders. Please contact the factory for details.

All dimensions are in millimetres unless otherwise stated.



**Mounting Styles**

**Mounting Styles and Where to Use Them**

See also application-specific mounting information on page 30.

**Extended Tie Rod Mountings – Styles TB, TC and TD**

**Application**

- straight line force transfer
- compression (push) – use cap end mountings TC or TD
- tension (pull) – use head end mountings TB or TD

**Benefits**

- ease of mounting where space is limited
- high efficiency – force is absorbed on cylinder’s centreline
- TD double-ended mounting allows brackets or switches to be attached to cylinder

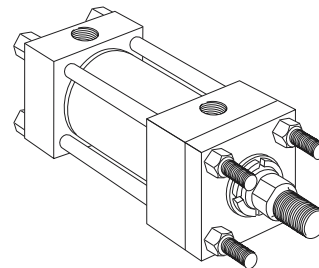

**Styles TB, TC, TD**  
See pages 10-11

TB

**Flange Mountings – Styles J, JB, JJ, H, HB and HH**

**Application**

- straight line force transfer
- compression (push) – use cap end mounting H, HB or HH
- tension (pull) – use head end mounting J, JB or JJ

**Benefits**

- exceptionally rigid mounting due to large flange area
- high efficiency – force is absorbed on cylinder’s centreline

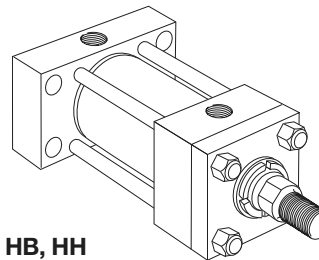

**Styles J, JB, JJ, H, HB, HH**  
See pages 12-15, 22-23

HH

**Foot Mountings – Style C, F, G**

**Application**

- straight line force transfer
- suitable for push or pull applications
- force is **not** absorbed on centreline – secure attachment, eg: a thrust key (page 30) and effective load guidance are vital

**Benefits**

- ease of mounting and adjustment

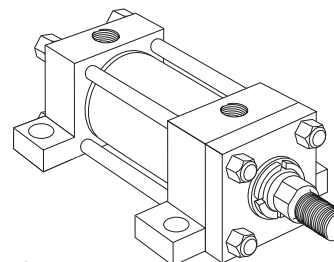

**Styles C, F, G**  
See pages 16-17 and 25

C

**Pivot Mountings – Styles BB and SBa**

**Application**

- curved path force transfer
- movement in a single plane – use fixed clevis style BB
- movement in more than one plane – use spherical bearing style SBd

**Benefits**

- ease of attachment – use with plain or spherical bearing at rod end
- greater flexibility for the machine designer
- self-alignment resists wear of cylinder’s bearing surfaces

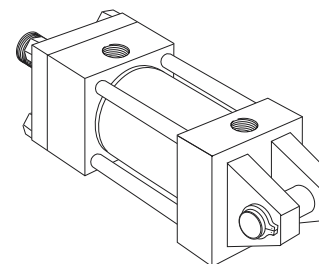

**Styles BB, SBa**  
See pages 18-19 and 25

BB

**Trunnion Mountings – Styles D, DB and DD**

**Application**

- curved path force transfer
- movement in a single plane
- compression (push) – use DB or DD mountings
- tension (pull) – use D or DD mountings

**Benefits**

- greater flexibility for the machine designer
- self-alignment resists wear of cylinder’s bearing surfaces
- high efficiency – force is absorbed on cylinder’s centreline
- ease of attachment – use with pivot mounting at rod end

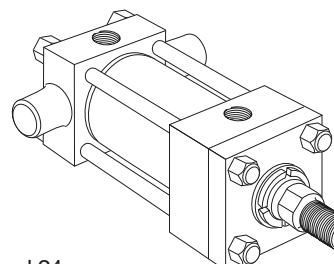

**Styles D, DB, DD**  
See pages 20-21 and 24

DB

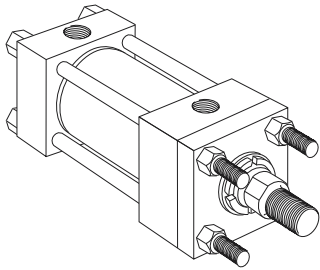

**Style TB**  
Tie Rods Extended Head End  
(NFFA Style MX3)

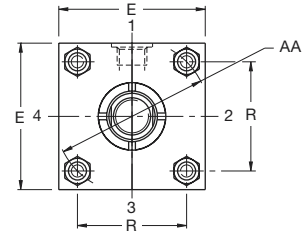
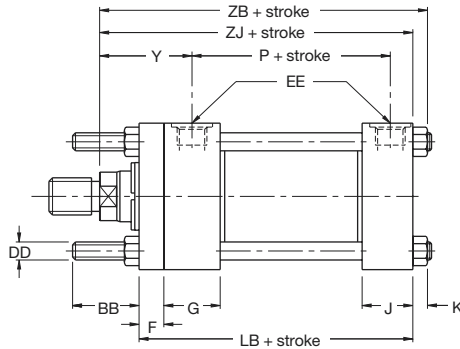

See Notes 1, 2

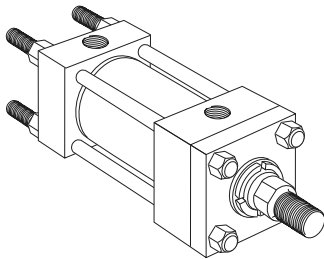

**Style TC**  
Tie Rods Extended Cap End  
(NFFA Style MX2)

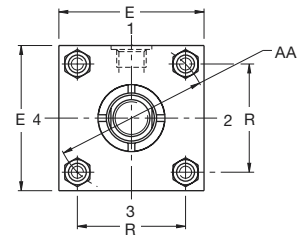
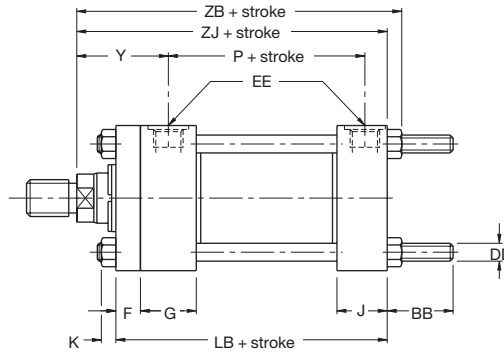

See Notes 1, 2

**Dimensions TB, TC & TD** See also rod end dimensions, page 3 & mounting information, page 30

Bore Ø	Rod No.	AA	BB	DD <sup>1</sup>	E	EE (BSPP)	F	G	J
38.1 (1½")	1	58.4	34.9	¾ - 24	63.5	G½	9.5	44.5	38.1
	2								
50.8 (2")	1	73.7	46.0	½ - 20	76.2	G½	15.9	44.5	38.1
	2								
63.5 (2½")	1	91.4	46.0	½ - 20	88.9	G½	15.9	44.5	38.1
	2								
	3								
82.6 (3¼")	1	116.8	58.7	⅝ - 18	114.3	G¾	19.1	50.8	44.5
	2								
	3								
101.6 (4")	1	137.2	58.7	⅝ - 18	127.0	G¾	22.2	50.8	44.5
	2								
	3								
127.0 (5")	1	177.8	81.0	⅞ - 14	165.1	G¾	22.2	50.8	44.5
	2								
	3								
	4								
152.4 (6")	1	205.7	92.1	1 - 14	190.5	G1	25.4	57.2	57.2
	2								
	3								
	4								
177.8 (7")	1	236.2	104.8	1⅞ - 12	215.9	G1¼	25.4	69.9	69.9
	2								
	3								
	4								
203.2 (8")	1	269.2	114.3	1¼ - 12	241.3	G1½	25.4	76.2	76.2
	2								
	3								
	4								
	5								

All dimensions are in millimetres unless otherwise stated.

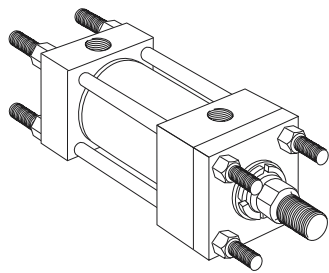

**Style TD**  
Tie Rods Extended Both Ends  
(NFPA Style MX1)

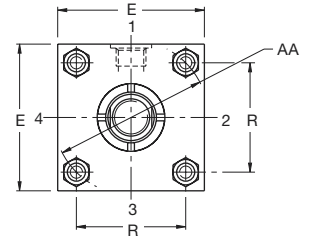
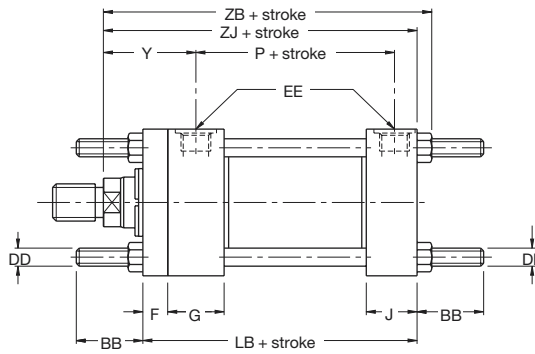

See Notes 1, 2

**Notes**

- 1 All tie rod threads (dimension DD) are UNF, with the exception of 1 - 14 which is UNS
- 2 Mounting nuts should be tightened to the torque values shown for tie rod nuts – see page 30

**Dimensions TB, TC & TD Continued**

Bore Ø	Rod No.	K max	R	Y	+ Stroke					
					LB	P	ZB max	ZJ		
38.1 (1½")	1	10	41.4	49	127.0	75	152.4	142.9		
	2								161.9	152.4
50.8 (2")	1	13	52.1	59	133.4	75	163.5	152.4		
	2								169.9	158.8
63.5 (2½")	1	13	64.8	59	136.5	78	166.7	156.6		
	2								179.4	168.3
	3								173.3	161.9
82.6 (3¼")	1	16	82.6	68	158.8	90	195.3	181.0		
	2								204.8	190.5
	3								201.6	187.3
101.6 (4")	1	16	97.0	76	168.3	97	208.0	193.7		
	2								217.5	203.2
	3								211.1	196.9
127.0 (5")	1	19	125.7	79	181.0	110	230.2	209.6		
	2								236.5	215.9
	3								236.5	215.9
	4								236.5	215.9
152.4 (6")	1	23	145.5	86	212.7	130	266.7	244.5		
	2									
	3									
	4									
177.8 (7")	1	26	167.1	92	241.3	146	298.5	273.0		
	2									
	3									
	4									
203.2 (8")	1	28	190.5	94	266.7	168	325.4	298.4		
	2									
	3									
	4									
	5									

All dimensions are in millimetres unless otherwise stated.

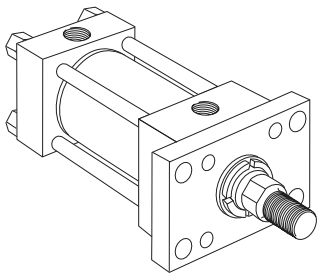

**Style J**  
Head Rectangular Flange  
(NFPA Style MF1)

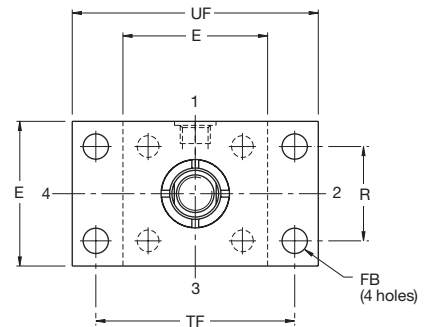
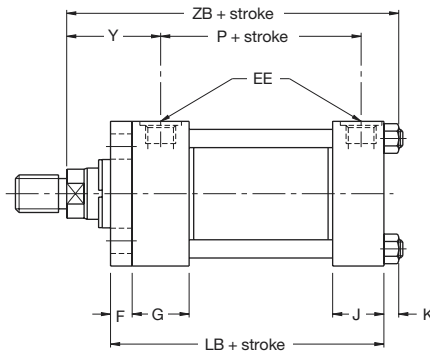

See Note 1

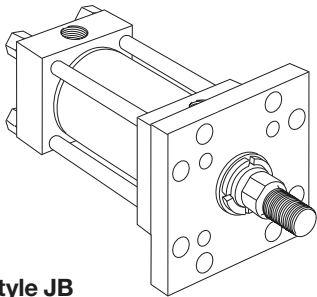

**Style JB**  
Head Square Flange  
(NFPA Style MF5)

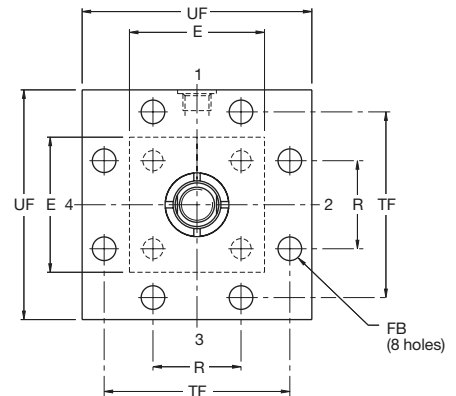
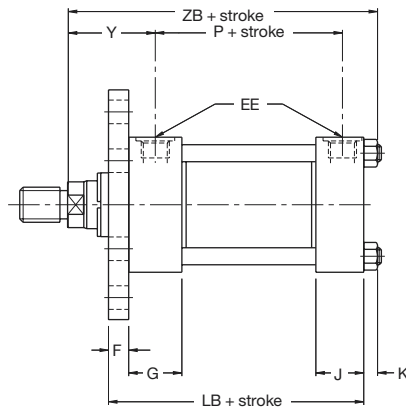

**Dimensions J, JB & JJ** See also rod end dimensions, page 3 & mounting information, page 30

Bore Ø	Rod No.	E	EE (BSP)	F	FB	G	J	K	KB	R
38.1 (1½")	1	63.5	G½	9.5	11.1	44.5	38.1	10	0.0	41.4
	2									
50.8 (2")	1	76.2	G½	15.9	14.3	44.5	38.1	13	0.0	52.1
	2									
63.5 (2½")	1	88.9	G½	15.9	14.3	44.5	38.1	13	0.0	64.8
	2									
	3									
82.6 (3¼")	1	114.3	G¾	19.1	17.5	50.8	44.5	16	6.4	82.6
	2									
	3									
101.6 (4")	1	127.0	G¾	22.2	17.5	50.8	44.5	16	6.4	97.0
	2									
	3									
	4									
127.0 (5")	1	165.1	G¾	22.2	23.8	50.8	44.5	19	3.2	125.7
	2									
	3									
	4									
152.4 (6")	1	190.5	G1	25.4	27.0	57.2	57.2	22	6.4	145.5
	2									
	3									
	4									
177.8 (7")	1	215.9	G1¼	25.4	30.2	69.9	69.9	24	6.4	167.1
	2									
	3									
	4									
203.2 (8")	1	241.3	G1½	25.4	33.3	76.2	76.2	27	6.4	190.5
	2									
	3									
	4									
	5									

All dimensions are in millimetres unless otherwise stated.

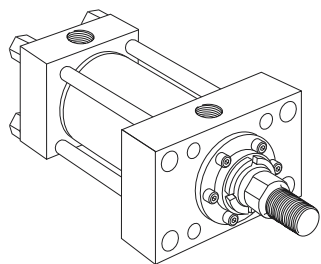

**Style JJ**  
Rectangular Head  
(NFPA Style ME5)

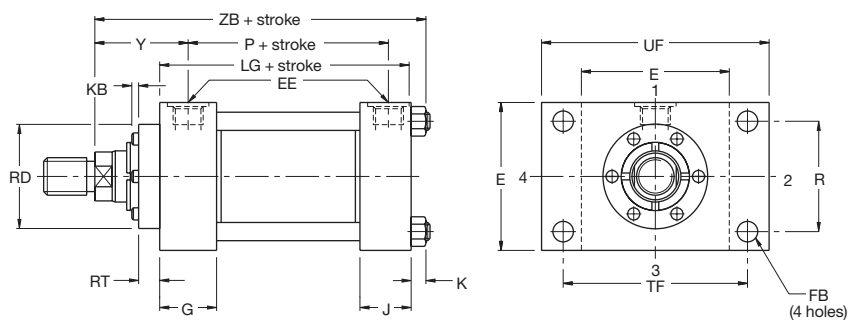

**Notes**

1 For maximum pressure ratings in push applications, see page 32

**Dimensions J, JB & JJ Continued**

Bore Ø	Rod No.	RD max	RT	TF	UF	Y	+ Stroke			
							LB	LG	P	ZB max
38.1 (1½")	1	54.0	9.5	87.3	108.0	49	127.0	117.5	75	152.4
	2	63.5	9.5							
50.8 (2")	1	63.5	9.5	104.8	130.2	59	133.4	117.5	75	163.5
	2	76.2	9.5							
63.5 (2½")	1	63.5	9.5	117.5	142.9	59	136.5	120.7	78	166.7
	2	88.9	9.5			71				179.4
	3	76.2	9.5			65				173.3
82.6 (3¼")	1	76.2	9.5	149.2	181.0	68	158.8	139.7	90	195.3
	2	101.6	15.9			79				204.8
	3	88.9	9.5			76				201.6
101.6 (4")	1	88.9	9.5	161.9	193.7	76	168.3	146.1	97	208.0
	2	114.3	15.9			86				217.5
	3	101.6	15.9			79				211.1
127.0 (5")	1	101.6	15.9	208.0	247.7	79	181.0	158.8	110	230.2
	2	146.1	15.9			86				236.5
	3	114.3	15.9			86				236.5
	4	133.4	15.9			86				236.5
152.4 (6")	1	114.3	15.9	239.7	285.8	86	212.7	187.3	130	266.7
	2	165.1	19.1							
	3	133.4	15.9							
	4	146.1	15.9							
177.8 (7")	1	133.4	15.9	269.9	320.7	92	241.3	215.9	146	298.5
	2	190.5	25.4							
	3	146.1	15.9							
	4	165.1	19.1							
203.2 (8")	1	146.1	15.9	300.0	355.6	94	266.7	241.3	168	325.4
	2	209.6	19.1							
	3	165.1	19.1							
	5	190.5	25.4							

All dimensions are in millimetres unless otherwise stated.

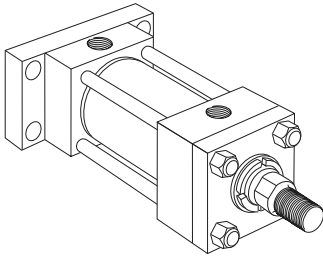

**Style H**  
Cap Rectangular Flange  
(NFPA Style MF2)

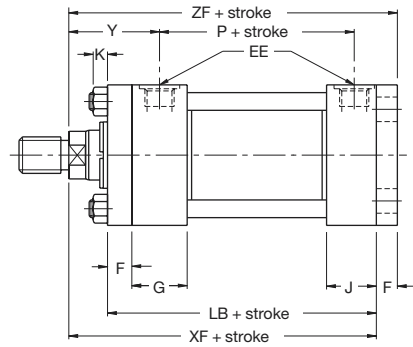
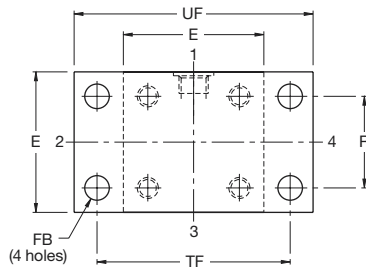

See Note 1

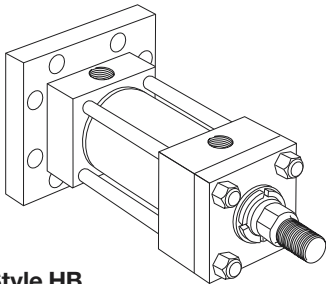

**Style HB**  
Cap Square Flange  
(NFPA Style MF6)

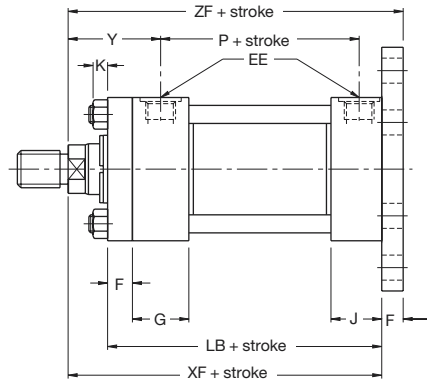
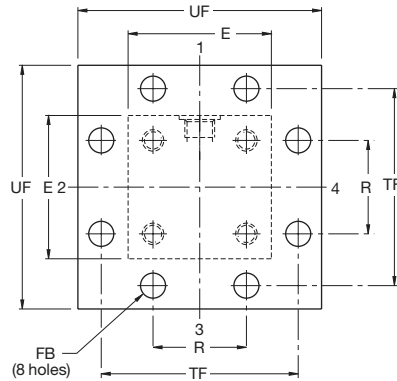

**Dimensions H, HB & HH** See also rod end dimensions, page 3 & mounting information, page 30

Bore Ø	Rod No.	E	EE (BSPP)	F	FB	G	J	K	R
38.1 (1½")	1	63.5	G½	9.5	11.1	44.5	38.1	10	41.4
	2								
50.8 (2")	1	76.2	G½	15.9	14.3	44.5	38.1	13	52.1
	2								
63.5 (2½")	1	88.9	G½	15.9	14.3	44.5	38.1	13	64.8
	2								
	3								
82.6 (3¼")	1	114.3	G¾	19.1	17.5	50.8	44.5	16	82.6
	2								
	3								
101.6 (4")	1	127.0	G¾	22.2	17.5	50.8	44.5	16	97.0
	2								
	3								
127.0 (5")	1	165.1	G¾	22.2	23.8	50.8	44.5	19	125.7
	2								
	3								
	4								
152.4 (6")	1	190.5	G1	25.4	27.0	57.2	57.2	22	145.5
	2								
	3								
	4								
177.8 (7")	1	215.9	G1¼	25.4	30.2	69.9	69.9	24	167.1
	2								
	3								
	4								
203.2 (8")	1	241.3	G1½	25.4	33.3	76.2	76.2	27	190.5
	2								
	3								
	4								
	5								

All dimensions are in millimetres unless otherwise stated.

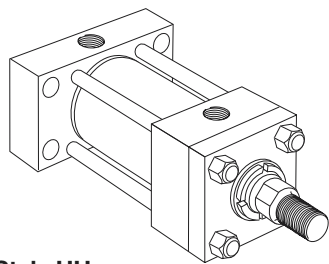

**Style HH**  
Rectangular Cap  
(NFA Style ME6)

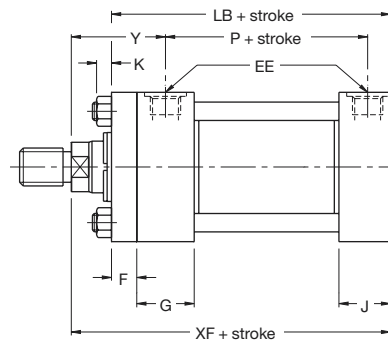
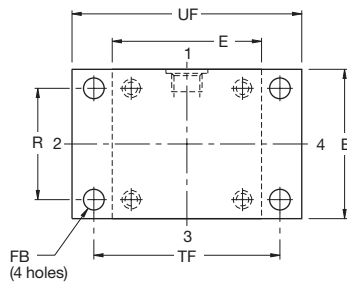

**Notes**

1 For maximum pressure ratings in pull applications, see page 36

**Dimensions H, HB & HH Continued**

Bore Ø	Rod No.	TF	UF	Y	+ Stroke					
					LB	P	XF	ZF		
38.1 (1 1/2")	1	87.3	108.0	49	127.0	75	142.9	152.4		
	2			59			152.4	161.9		
50.8 (2")	1	104.8	130.2	59	133.4	75	152.4	168.3		
	2			65			158.8	174.6		
63.5 (2 1/2")	1	117.5	142.9	59	136.5	78	156.6	171.5		
	2			71			168.3	184.2		
	3			65			161.9	177.8		
82.6 (3 1/4")	1	149.2	181.0	68	158.8	90	181.0	200.0		
	2			79			190.5	209.6		
	3			76			187.3	206.4		
101.6 (4")	1	161.9	193.7	76	168.3	97	193.7	215.9		
	2			86			203.2	225.4		
	3			79			196.9	219.1		
127.0 (5")	1	208.0	247.7	79	181.0	110	209.6	231.8		
	2			86			215.9	238.1		
	3			86			215.9	238.1		
	4			86			215.9	238.1		
152.4 (6")	1	239.7	285.8	86	212.7	130	244.5	269.9		
	2									
	3									
	4									
177.8 (7")	1	269.9	320.7	92	241.3	146	273.0	298.5		
	2									
	3									
	4									
203.2 (8")	1	300.0	355.6	94	266.7	168	298.5	323.9		
	2									
	3									
	4									
	5									

All dimensions are in millimetres unless otherwise stated.

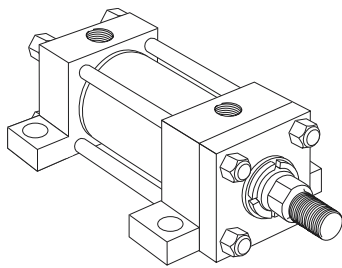

**Style C**  
Side Lug Mounting  
(NFFA Style MS2)

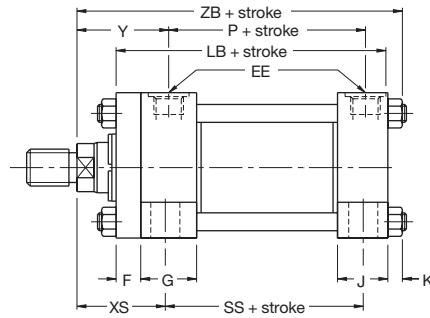

See Notes 1, 3, 4

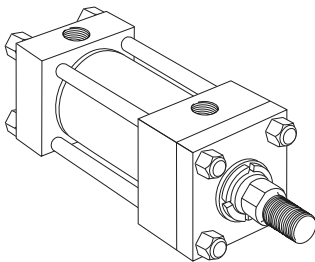
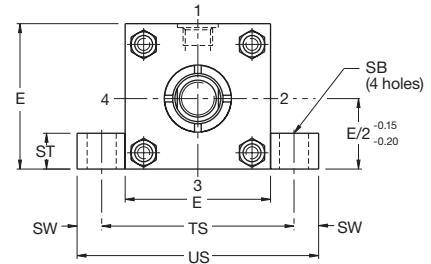

**Style F**  
Side Tapped Mounting  
(NFFA Style MS4)

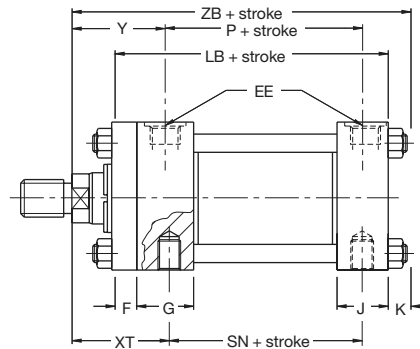

See Notes 1, 2

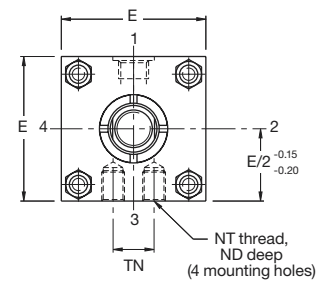

**Dimensions C, F & G** See also rod end dimensions, page 3 & mounting information, page 30

Bore Ø	Rod No.	E	EB	EE (BSPP)	EL	EO	ES	ET	F	G	J	K	ND	NT <sup>2</sup>	R	SB <sup>3</sup>	ST
38.1 (1½")	1	63.5	11.5	G½	22.2	9.5	24	21	9.5	44.5	38.1	10	12	M10	41.4	11	12.7
	12																
50.8 (2")	1	76.2	14.3	G½	23.8	12.7	24	24	15.9	44.5	38.1	13	15	M12	52.1	14	19.1
	11																
63.5 (2½")	1	88.9	14.3	G½	23.8	12.7	24	24	15.9	44.5	38.1	13	14	M16	64.8	22	25.4
	2												12				
	3												14				
82.6 (3¼")	1	114.3	17.5	G¾	28.6	15.9	32	31	19.1	50.8	44.5	16	22	M20	82.6	22	25.4
	2												17				
	3												22				
101.6 (4")	1	127.0	17.5	G¾	28.6	15.9	32	29	22.2	50.8	44.5	16	25	M24	97.0	26	31.8
	2												17				
	3												25				
127.0 (5")	1	165.1	23.8	G¾	38.1	19.1	38	38	22.2	50.8	44.5	19	28	M24	125.7	26	31.8
	2												25				
	3												28				
	4												28				
152.4 (6")	1	190.5	27.0	G1	42.9	22.2	45	45	25.4	57.2	57.2	22	44	M30	145.5	33	38.1
	2												31				
	3												41				
	4												38				
177.8 (7")	1	215.9	30.2	G1¼	46.0	25.4	50	48	25.4	69.9	69.9	24	54	M42	167.1	39	44.5
	2												28				
	3												54				
	4												44				
203.2 (8")	1	241.3	33.3	G1½	50.8	28.6	50	48	25.4	76.2	76.2	27	57	M42	190.5	39	44.5
	2												38				
	3												57				
	4												44				
	5												44				

All dimensions are in millimetres unless otherwise stated.



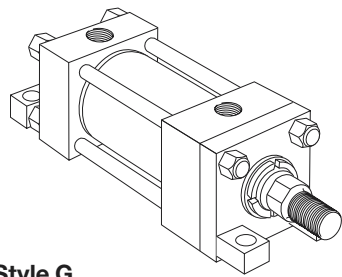

**Style G**  
Side End Lug  
(NFFA Style MS7)

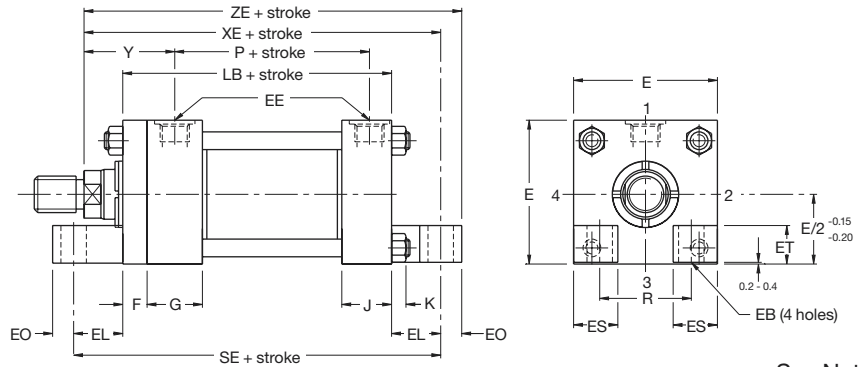

See Note 1

**Notes**

- 1 Consider the use of a thrust key with this mounting – see page 30
- 2 Tapped mounting holes are metric (coarse pitch series)
- 3 Upper surfaces of lugs are machined for socket head screws
- 4 Style C cylinders can be supplied with the cylinder ports arranged for mounting and sealing to a manifold surface – see page 31

**Dimensions C, F & G Continued**

Bore Ø	Rod No.	sw	TN	TS	US	XS	XT	Y	+ Stroke							
									LB	P	SE	SN	SS	XE	ZB max	ZE
38.1 (1½")	1	9.5	18.0	82.6	101.6	34.9	50.8	49	127.0	75	171.5	73.0	98.4	165.1	152.4	174.6
	2													174.6	161.9	184.2
50.8 (2")	1	12.7	23.8	101.6	127.0	47.6	60.3	59	133.4	75	181.0	73.0	92.1	176.2	163.5	188.9
	2													182.6	169.9	195.3
63.5 (2½")	1	17.5	32.0	123.8	158.8	52.4	60.3	59	136.5	78	184.2	76.2	85.7	179.4	166.7	192.1
	2													192.1	179.4	204.8
	3													185.7	173.3	198.4
82.6 (3¼")	1	17.5	38.1	149.2	184.2	58.7	69.9	68	158.8	90	215.9	88.9	104.8	209.6	195.3	225.4
	2													219.1	204.8	235.0
	3													215.9	201.6	231.8
101.6 (4")	1	22.2	52.4	171.5	215.9	69.9	76.2	76	168.3	97	225.4	95.3	101.6	222.3	208.0	238.1
	2													231.8	217.5	247.7
	3													225.4	211.1	241.3
127.0 (5")	1	22.2	74.6	209.6	254.0	73.0	79.4	79	181.0	110	257.2	108.0	114.3	247.7	230.2	266.7
	2													254.0	236.5	273.1
	3													254.0	236.5	273.1
	4													254.0	236.5	273.1
152.4 (6")	1	28.6	84.1	247.7	304.8	85.7	88.9	86	212.7	130	298.5	130.2	130.2	287.3	266.7	309.6
	2															
	3															
	4															
177.8 (7")	1	34.9	90.0	285.8	355.6	92.1	96.8	92	241.3	146	333.4	149.2	146.1	319.1	298.5	344.5
	2															
	3															
	4															
203.2 (8")	1	34.9	105.0	311.2	381.0	92.1	100.0	94	266.7	168	368.3	168.3	171.5	349.3	325.4	377.8
	2															
	3															
	4															
	5															

All dimensions are in millimetres unless otherwise stated.

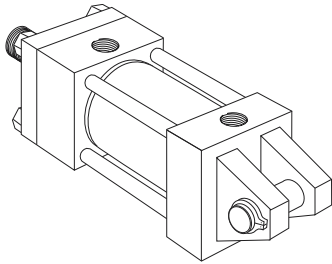

**Style BB**  
Cap Fixed Clevis  
(NFPA Style MP1)

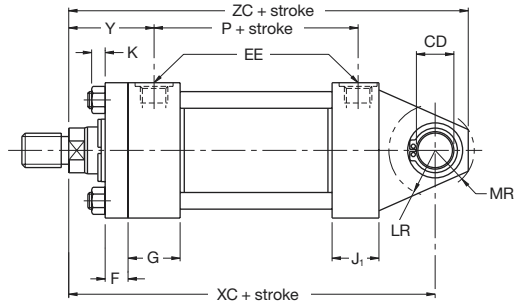
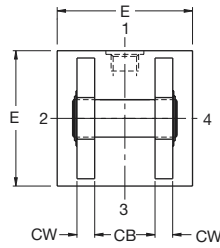

See Note 1

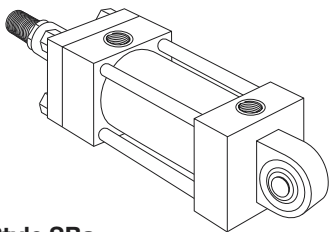

**Style SBa**  
Spherical Bearing  
(ISO 6982 and CETOP RP88H)

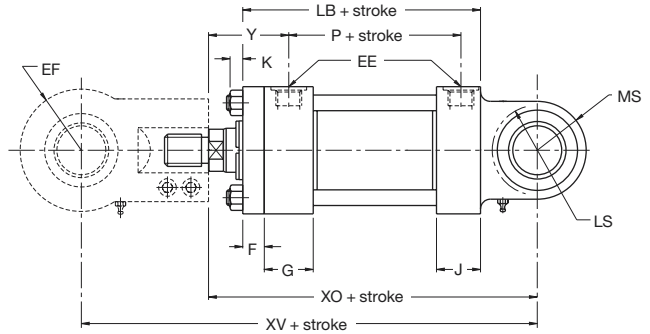
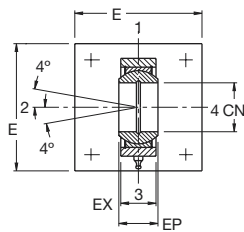

See Notes 2, 3, 4, 5

**Dimensions BB & SBa** See also rod end dimensions, page 3 & mounting information, page 30

Bore Ø	Rod No.	CB	CD <sup>+0.00</sup> / <sub>-0.05</sub>	CN H7	CW	E	EE (BSPP)	EF max	EP	EX	F	G	J	J <sub>1</sub>
38.1 (1½")	1	19.8	12.73	20	12.7	63.5	G½	25	20	18	9.5	44.5	38.1	42
	2													
50.8 (2")	1	32.5	19.08	25	15.9	76.2	G½	31	25	22	15.9	44.5	38.1	42
	2													
63.5 (2½")	1	32.5	19.08	32	15.9	88.9	G½	38	32	28	15.9	44.5	38.1	42
	2													
	3													
82.6 (3¼")	1	38.9	25.43	40	19.1	114.3	G¾	49	40	35	19.1	50.8	44.5	50
	2													
	3													
101.6 (4")	1	51.6	34.95	50	25.4	127.0	G¾	59	50	40	22.2	50.8	44.5	50
	2													
	3													
127.0 (5")	1	65.0	44.48	63	31.8	165.1	G¾	71	63	52	22.2	50.8	44.5	50
	2													
	3													
	4													
152.4 (6")	1	65.0	50.83	80	31.8	190.5	G1	90	80	60	25.4	57.2	57.2	61
	2													
	3													
	4													
177.8 (7")	1	77.8	63.53	-	38.1	215.9	G1¼	-	-	-	25.4	69.9	69.9	74
	2													
	3													
	4													
203.2 (8")	1	77.8	76.23	-	38.1	241.3	G1½	-	-	-	25.4	76.2	76.2	78
	2													
	3													
	4													
	5													

All dimensions are in millimetres unless otherwise stated.

**Notes**

- 1 Supplied complete with pivot pin
- 2 Maximum pressure rating 160 bar
- 3 For matching pin sizes specify rod end Style 7, see pages 3 and 29
- 4 Pivot pin not supplied
- 5 For spherical bearing mountings on cylinders above 152.4mm (6") bore, please consult the factory

**Dimensions BB & SBa Continued**

Bore Ø	Rod No.	K	LR	LS	MR	MS max	Y	+ Stroke					
								LB	P	XC	XO <sup>5</sup>	XV	ZC
38.1 (1½")	1	10	14.3	23	15.9	25	49	127.0	75	161.9	–	–	177.8
	59						171.5			182.5	234.5	187.4	
50.8 (2")	1	13	25.4	26	23.8	31	59	133.4	75	184.2	182.5	247.5	208.0
	65						190.5			188.8	253.8	214.3	
63.5 (2½")	1	13	23.8	32	23.8	38	59	136.5	78	187.3	–	–	211.1
	71						200.0			217.2	297.2	223.8	
	65						193.7			210.8	290.8	217.5	
82.6 (3¼")	1	16	31.8	41	30.2	50	68	158.8	90	219.1	–	–	249.3
	79						228.6			240.6	337.6	258.8	
	76						225.4			237.4	334.4	255.6	
101.6 (4")	1	16	44.5	50	41.3	61	76	168.3	97	247.7	–	–	289.0
	86						257.2			266.2	386.2	298.4	
	79						250.8			259.9	379.9	292.1	
127.0 (5")	1	19	52.4	62	54.0	71	79	181.0	110	266.7	–	–	320.7
	86						273.1			282.9	422.9	327.1	
	86						273.1			282.9	422.9	327.1	
	86						273.1			–	–	327.1	
152.4 (6")	1	22	58.7	78	60.3	93	86	212.7	130	308.0	–	–	368.3
	2										358.3	538.3	
	3										–	–	
	4										358.3	538.3	
177.8 (7")	1	24	69.9	–	73.0	–	92	241.3	146	349.3	–	–	422.3
	2										–	–	
	3										–	–	
	4										–	–	
203.2 (8")	1	27	82.6	–	79.4	–	94	266.7	168	381.0	–	–	460.4
	2										–	–	
	3										–	–	
	4										–	–	
	5										–	–	

All dimensions are in millimetres unless otherwise stated.

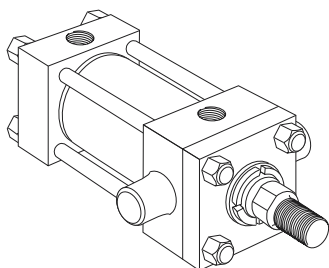

**Style D**  
Head Trunnion  
(NFFPA Style MT1)

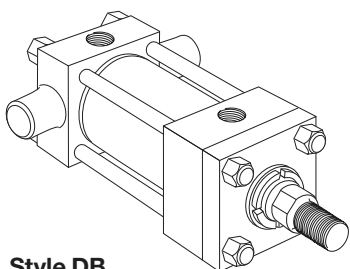
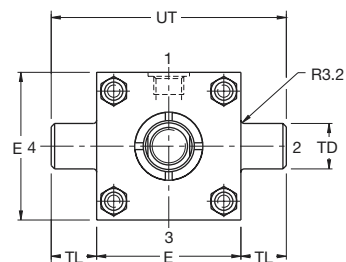
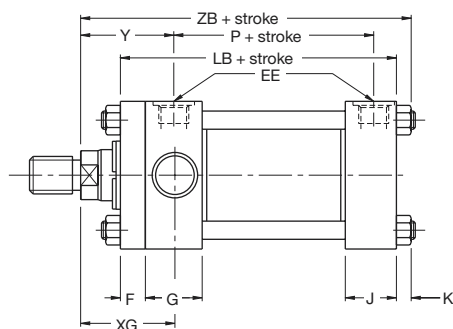

**Style DB**  
Cap Trunnion  
(NFFPA Style MT2)

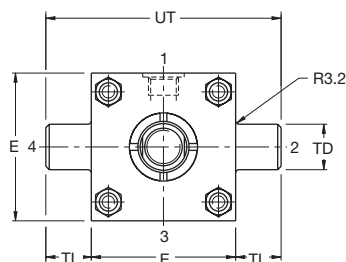
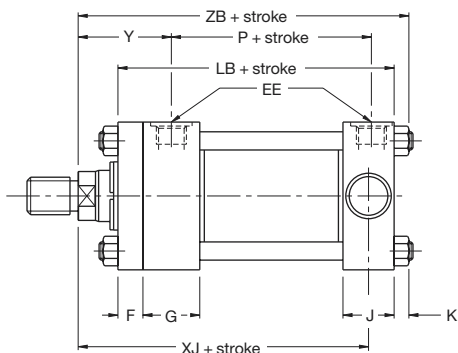

**Dimensions D, DB & DD** See also rod end dimensions, page 3 & mounting information, page 30

Bore Ø	Rod No.	BD	E	EE (BSPP)	F	G	J	K	TD <sup>+0.00</sup> <sub>-0.03</sub>	TL	TM	TY
38.1 (1½")	1	31.8	63.5	G½	9.5	44.5	38.1	10	25.40	25.4	76.2	69.9
	2											
50.8 (2")	1	38.1	76.2	G½	15.9	44.5	38.1	13	34.93	34.9	88.9	82.6
	2											
63.5 (2½")	1	38.1	88.9	G½	15.9	44.5	38.1	13	34.93	34.9	101.6	95.2
	2											
	3											
82.6 (3¼")	1	50.8	114.3	G¾	19.1	50.8	44.5	16	44.45	44.5	127.0	120.7
	2											
	3											
101.6 (4")	1	50.8	127.0	G¾	22.2	50.8	44.5	16	44.45	44.5	139.7	133.4
	2											
	3											
127.0 (5")	1	50.8	165.1	G¾	22.2	50.8	44.5	19	44.45	44.5	177.8	171.5
	2											
	3											
	4											
152.4 (6")	1	76.2	190.5	G1	25.4	57.2	57.2	22	50.8	50.8	215.9	196.9
	2											
	3											
	4											
177.8 (7")	1	76.2	215.9	G1¼	25.4	69.9	69.9	24	63.5	63.5	247.7	222.3
	2											
	3											
	4											
203.2 (8")	1	88.9	241.3	G1½	25.4	76.2	76.2	27	76.2	76.2	279.4	247.7
	2											
	3											
	4											
	5											

All dimensions are in millimetres unless otherwise stated.

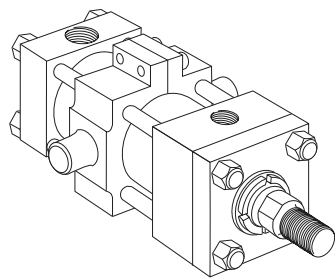

**Style DD**  
Intermediate Fixed Trunnion  
(NFPA Style MT4)

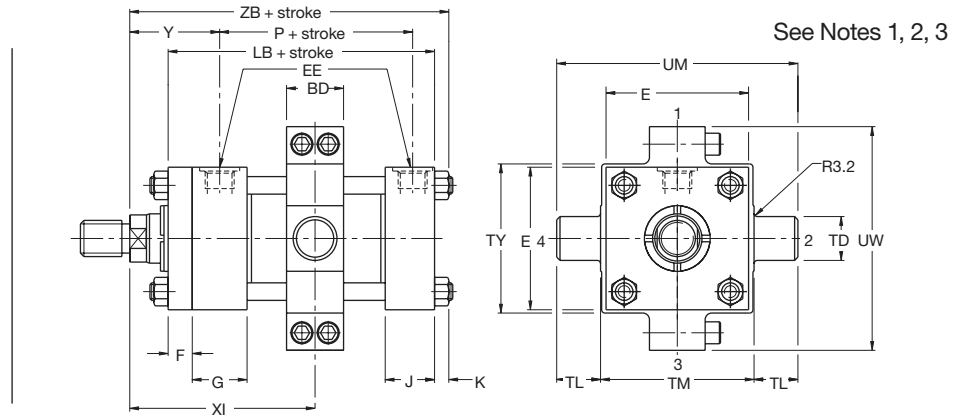

**Notes**

- 1 Note the minimum strokes from the table below
- 2 XI dimension to be specified by customer, note minimum dimension
- 3 A one-piece trunnion is fitted to 38.1mm (1½"), 50.8mm (2") and 63.5mm (2½") bore cylinders

**Dimensions D, DB & DD Continued**

Bore Ø	Rod No.	UM	UT	UW <sup>3</sup>	XG	Min. <sup>2</sup> XI	Y	Style DD min stroke	+ Stroke			
									LB	P	XJ	ZB max
38.1 (1½")	1	127.0	114.3	-	47.6 57.2	85.7 95.3	49 59	0.0	127.0	75	123.8 133.4	152.4 161.9
	2											
50.8 (2")	1	158.8	146.1	-	57.2 63.5	98.4 104.8	59 65	3.2	133.4	75	133.4 139.7	163.5 169.9
	2											
63.5 (2½")	1	171.5	158.8	-	57.2 69.9 63.5	98.4 111.1 104.8	59 71 65	0.0	136.5	78	136.5 149.2 142.9	166.7 179.4 173.3
	2											
	3											
82.6 (3¼")	1	215.9	203.2	171.5	66.7 76.2 73.0	117.5 127.0 123.8	68 79 76	6.4	158.8	90	158.8 168.3 165.1	195.3 204.8 201.6
	2											
	3											
101.6 (4")	1	228.6	215.9	184.2	73.0 82.6 76.2	123.8 133.4 127.0	76 86 79	0.0	168.3	97	171.5 181.0 174.6	208.0 217.5 211.1
	2											
	3											
	4											
127.0 (5")	1	266.7	254.0	228.6	76.2 82.6 82.6 82.6	127.0 133.4 133.4 133.4	79 86 86 86	0.0	181.0	110	187.3 193.7 193.7 193.7	230.2 236.5 236.5 236.5
	2											
	3											
	4											
152.4 (6")	1	317.5	292.1	260.4	85.7	152.4	86	3.2	212.7	130	212.7	266.7
	2											
	3											
	4											
177.8 (7")	1	374.7	342.9	292.1	92.1	165.1	92	0.0	241.3	146	238.1	298.5
	2											
	3											
	4											
203.2 (8")	1	431.8	393.7	323.9	95.3	177.8	94	0.0	266.7	168	260.4	325.4
	2											
	3											
	4											
	5											

All dimensions are in millimetres unless otherwise stated.

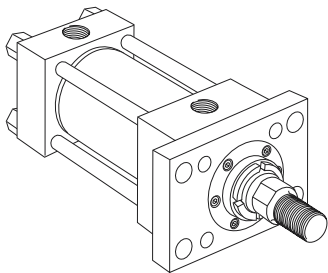

**Style J**  
Head Rectangular Flange  
(NFPA Style MF1)

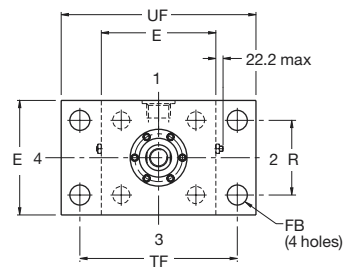
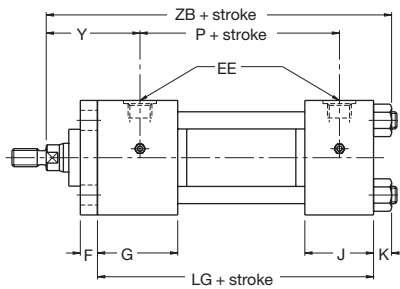

See Notes 1, 2, 3, 4

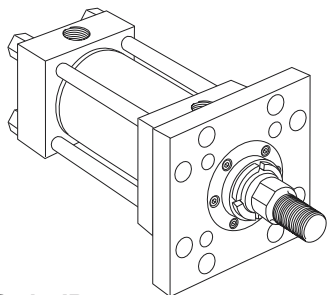

**Style JB**  
Head Square Flange  
(NFPA Style MF5)

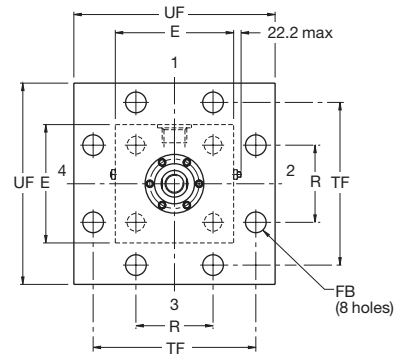
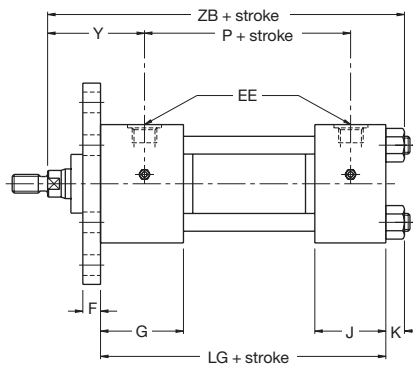

See Notes 1, 2, 4

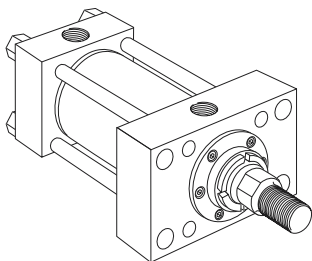

**Style JJ**  
Rectangular Head  
(NFPA Style ME5)

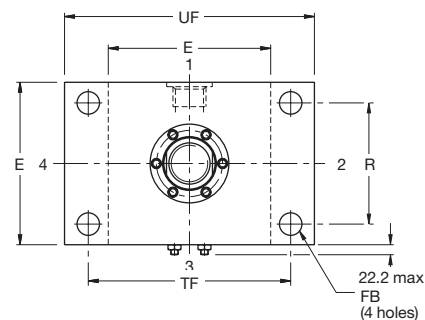
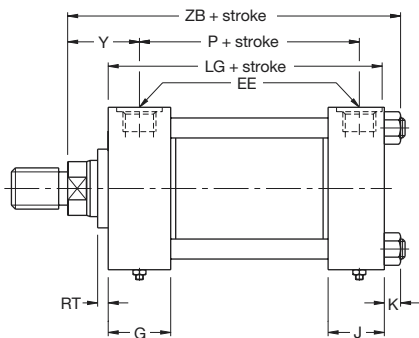

See Notes 1, 2, 4

**Dimensions J, JB & JJ** See also rod end dimensions, page 40 & mounting information, page 30

Bore Ø	Rod No.	E	EE <sup>4</sup> (BSPP)	F	FB	G	J	K	R	RT	TF	UF	Y	+ Stroke		
														LG	P	ZB max
254.0 (10")	1	320.7	G2	42.9	46.0	93.7	93.7	39	244.3	25.4	403.2	482.6	120.7	308.0	215.9	422.3
	2															
304.8 (12")	1	377.8	G2½	49.2	52.4	112.7	112.7	See note 2	290.8	33.3	469.9	558.8	136.5	368.3	257.2	449.3
	2															

**Notes**

1 The dimensional drawings above show 254mm (10") bore models fitted with four tie rods, but can also be used to determine dimensions for 304.8mm (12") bore models fitted with 16 tie rods

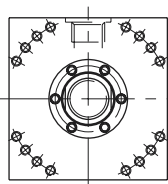

- 2 Tie rod nuts are flush with cap on 304.8mm (12") cylinders
- 3 For maximum pressure ratings, see page 32
- 4 Flange ports to ISO 6162 are also available – see page 35

All dimensions are in millimetres unless otherwise stated.

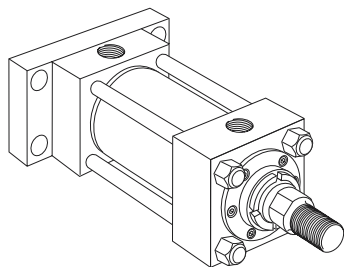

**Style H**  
Cap Rectangular Flange  
(NFFA Style MF2)

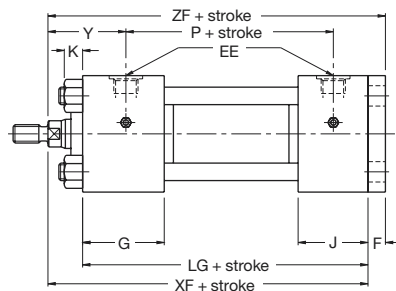
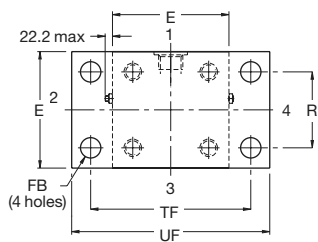

See Notes 1, 2, 3, 4

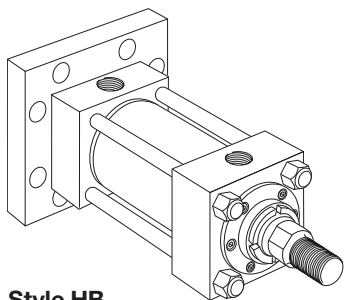

**Style HB**  
Cap Square Flange  
(NFFA Style MF6)

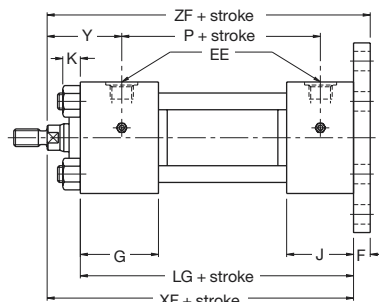
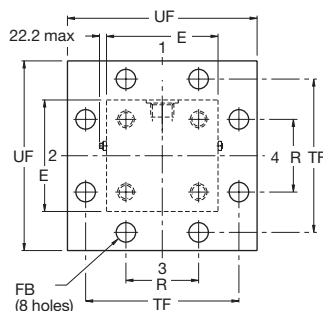

See Notes 1, 2, 4

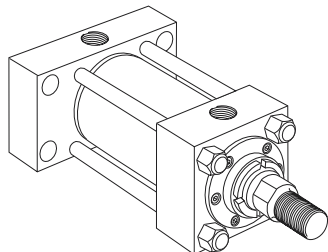

**Style HH**  
Rectangular Cap  
(NFFA Style ME6)

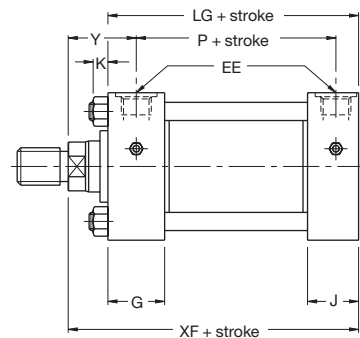
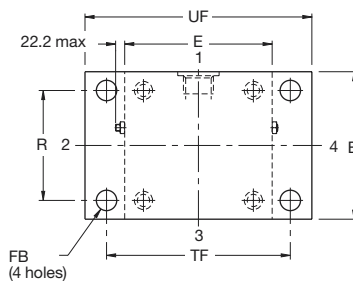

See Notes 1, 2, 4

**Dimensions H, HB & HH** See also rod end dimensions, page 40 & mounting information, page 30

Bore Ø	Rod No.	E	EE <sup>4</sup> (BSPP)	F	FB	G	J	K	R	TF	UF	Y	+ Stroke			
													LG	P	XF	ZF
254.0 (10")	1	320.7	G2	42.9	46.0	93.7	93.7	39	244.3	403.2	482.6	120.7	308.0	215.9	382.6	425.5
	2															
304.8 (12")	1	377.8	G2½	49.2	52.4	112.7	112.7	See note 2	290.8	469.9	558.8	136.5	368.3	257.2	449.3	498.5
	2															

**Notes**

- The dimensional drawings above show 254mm (10") bore models fitted with four tie rods, but can also be used to determine dimensions for 304.8mm (12") bore models fitted with 16 tie rods

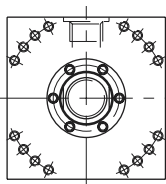

- Tie rod nuts are flush with head on 304.8mm (12") cylinders
- For maximum pressure ratings, see page 32
- Flange ports to ISO 6162 are also available – see page 35

All dimensions are in millimetres unless otherwise stated.

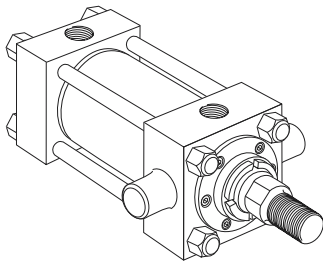

**Style D**  
 Head Trunnion  
 (NFPA Style MT1)

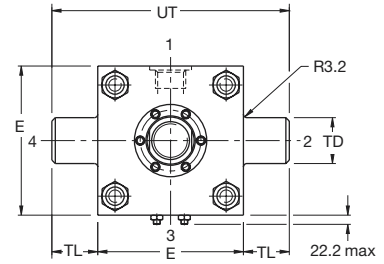
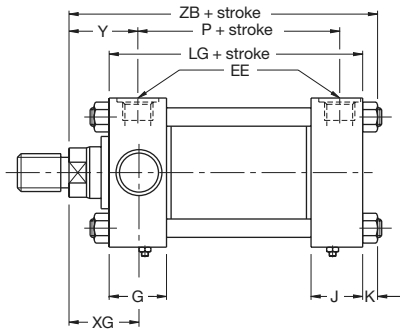

See Notes 1, 2, 4

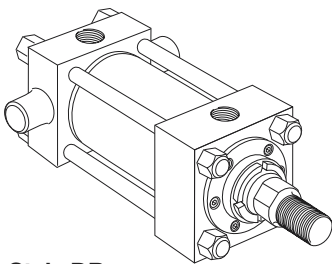

**Style DB**  
 Cap Trunnion  
 (NFPA Style MT2)

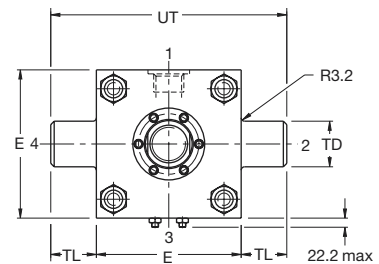
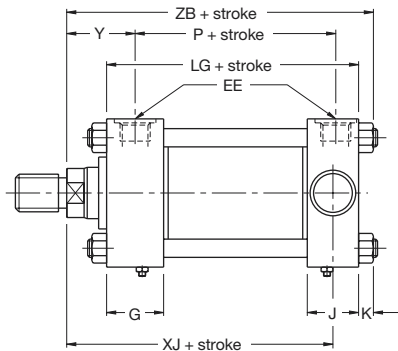

See Notes 1, 2, 4

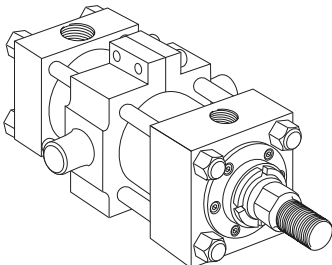

**Style DD**  
 Intermediate Fixed Trunnion  
 (NFPA Style MT4)

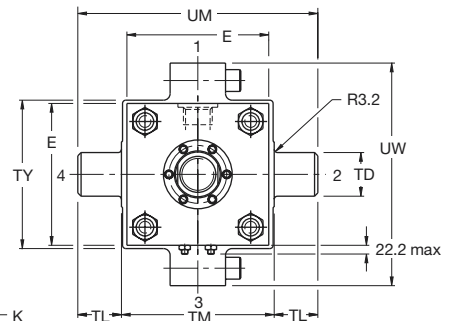
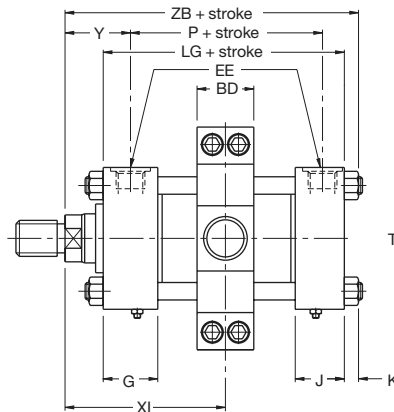

See Notes 1, 2, 3, 4

**Dimensions D, DB, & DD** See also rod end dimensions, page 40 & mounting information, page 30

Bore Ø	Rod No.	BD	E	EE <sup>4</sup> (BSPP)	G & J	K	TD <sup>+0.000/-0.025</sup>	TL	TM	TY	UM	UT	UW	Min. <sup>3</sup> XI	XG & Y	+ Stroke			
																LG	P	XJ	ZB max
254.0 (10")	1	114.3	320.7	G2	93.7	39	88.9	88.9	355.6	330.2	533.4	498.5	444.5	225.4	120.7	308.0	215.9	336.6	421.6
	2																		
304.8 (12")	1	139.7	377.8	G2½	112.7	See note 2	101.6	101.6	419.1	393.7	622.3	581.0	527.1	263.5	136.5	368.3	257.2	393.7	449.3
	2																		

**Notes**

1 The dimensional drawings above show 254mm (10") bore models fitted with four tie rods, but can also be used to determine dimensions for 304.8mm (12") bore models fitted with 16 tie rods

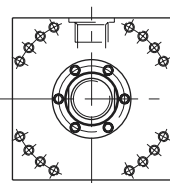

- 2 Tie rod nuts are flush with head and cap on 304.8mm (12") cylinders
- 3 Dimension XI to be specified by customer
- 4 Flange ports to ISO 6162 are also available – see page 35

All dimensions are in millimetres unless otherwise stated.



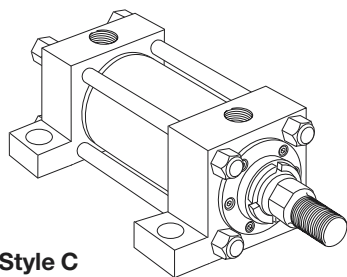

**Style C**  
Side Lug  
(NFFPA Style MS2)

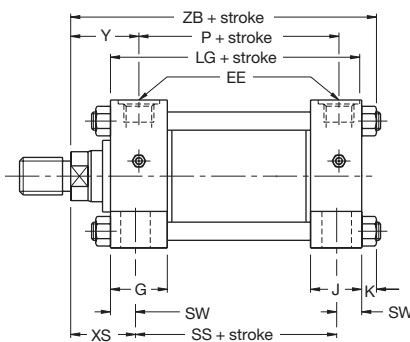

See Notes 1, 2, 3, 4

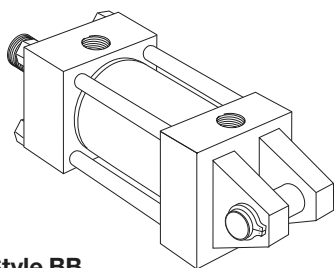
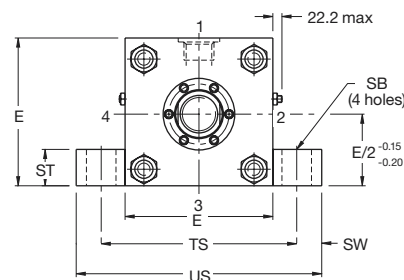

**Style BB**  
Cap Fixed Clevis  
(NFFPA Style MP1)

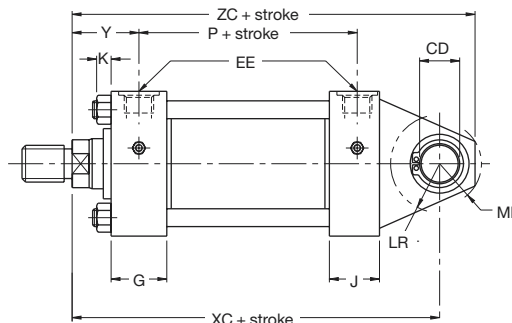
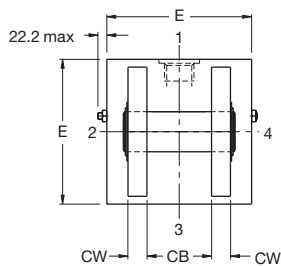

See Notes 1, 2, 4, 5

**Dimensions C & BB** See also rod end dimensions, page 40 & mounting information, page 30

Bore Ø	Rod No.	CB	CD <sup>+0.00/-0.08</sup>	CW	E	EE <sup>4</sup> (BSPP)	G & J	K	LR	MR	SB	ST	SW	TS	US	XS	Y	+ Stroke					
																		LG	P	SS	XC	ZB max	ZC
254.0 (10")	1	101.6	88.93	50.8	320.7	G2	93.7	39	98.4	90.0	39	57.2	41.3	403.2	485.8	115.9	120.7	308.0	215.9	225.4	483.4	421.6	573.1
	2																						
304.8 (12")	1	114.3	101.63	57.2	377.8	G2½	112.7	See note 2	111.1	111.1	39	76.2	50.8	479.4	581.0	131.8	136.5	368.3	257.2	266.7	563.6	449.3	665.2
	2																						

**Notes**

- The dimensional drawings above show 254mm (10") bore models fitted with four tie rods, but can also be used to determine dimensions for 304.8mm (12") bore models fitted with 16 tie rods

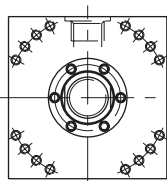

- Tie rod nuts are flush with head and cap on 304.8mm (12") cylinders
- Style C cylinders can be supplied with the cylinder ports arranged for mounting and sealing to a manifold surface – see page 31
- Flange ports to ISO 6162 are also available – see page 35
- Supplied complete with pivot pin

All dimensions are in millimetres unless otherwise stated.

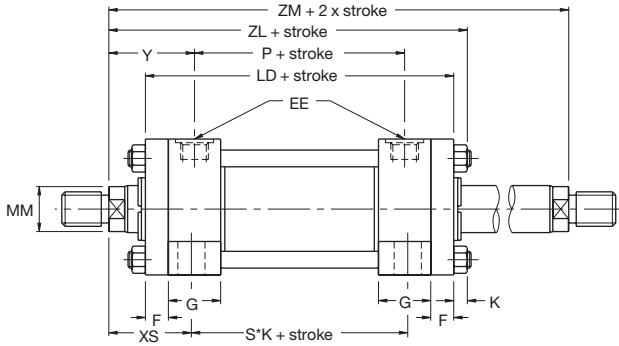

**Double Rod Cylinders** Available with Styles TB, TD, 38.1 to 203.2mm Bores J, JB, JJ, C, F, D, DD, and G

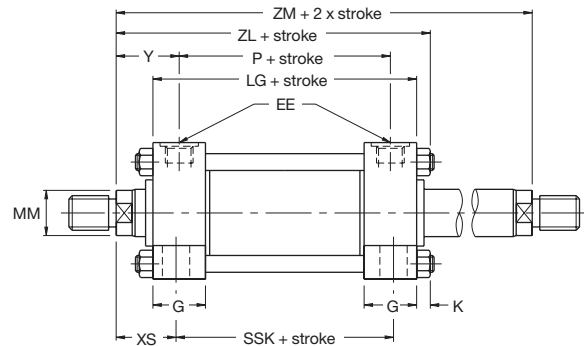

**Double Rod Cylinders** Available with Styles J, JB, 254 and 304.8mm Bores JJ, C, D, and DD

**Mounting Styles and Codes**

Double rod cylinders are denoted by a 'K' in the model code, shown on page 41.

**Dimensions**

To obtain dimensional information for double rod cylinders, first select the desired mounting style by referring to the corresponding single rod models shown on the preceding pages. Dimensions for the appropriate single rod model should be supplemented by those from the table opposite to provide a full set of dimensions.

**Rod Strength**

Double rod cylinders employ two separate piston rods, with one screwed into the end of the other within the piston rod assembly. As a result, one piston rod is stronger than the other. The stronger rod is identified by the letter 'K' stamped on its end, and its pressure limitations with a 4:1 design factor are identical to those shown in the table on page 32 for the equivalent single rod assembly. The weaker rod should always be used for the lighter duty. Pressure limitations for the weaker rod in pull applications at a 4:1 design factor are also identical to those on page 32, except for the bore sizes shown in the table below.

Bore Ø	Rod Diameter	4 : 1 Design Factor (bar)
63.5 (2½")	25.4 (1")	95
82.6 (3¼")	34.9 (1¾")	115

Bore Ø	Rod No.	MM Rod Diameter	+ Stroke					+ 2x Stroke
			LD <sup>1</sup> LG <sup>2</sup>	ZL	SEK <sup>3</sup>	SNK <sup>4</sup>	SSK <sup>5</sup>	ZM
38.1 (1½")	1	15.9 (5/8")						
	2	25.4 (1")						
50.8 (2")	1	25.4 (1")						
	2	34.9 (1¾")						
63.5 (2½")	1	25.4 (1")						
	2	44.5 (1¾")						
	3	34.9 (1¾")						
82.6 (3¼")	1	34.9 (1¾")						
	2	50.8 (2")						
	3	44.5 (1¾")						
101.6 (4")	1	44.5 (1¾")						
	2	63.5 (2½")						
	3	50.8 (2")						
127.0 (5")	1	50.8 (2")						
	2	88.9 (3½")						
	3	63.5 (2½")						
	4	76.2 (3")						
152.4 (6")	All	All						
177.8 (7")	All	All						
203.2 (8")	All	All						
254.0 (10")	1	127.0 (5")						
304.8 (12")	1	139.7 (5½")						

**Combination Rods**

Double rod cylinders with rods of differing rod diameters are also available. Please contact the factory for details.

**Cushioning**

Double rod cylinders can be supplied with cushions at either or both ends. Cushioning requirements should be specified by inserting a 'C' in the ordering code – see page 41. Double rod cylinders with cushioning are supplied with floating cushion sleeves as standard.

<sup>1</sup> Use LD dimensions for 38.1mm to 203.2mm (1½" to 8") bore sizes  
<sup>2</sup> Use LG dimensions for 254.0mm & 304.8mm (10" & 12") bore sizes  
<sup>3</sup> SEK dimensions apply to mounting style KG only  
<sup>4</sup> SNK dimensions apply to mounting style KF only  
<sup>5</sup> SSK dimensions apply to mounting style KC only

**Style 9 Rod Ends**

If a stroke of less than 25mm on bore sizes up to 82.6mm (3¼"), or a stroke of less than 100mm on bore sizes of 101.6mm (4") and over, is required, where Style 9 rod ends are required at both ends, please consult the factory.

All dimensions are in millimetres unless otherwise stated.

**Accessory Selection**

Accessories for the rod end of a cylinder are selected by reference to the rod end thread, shown on pages 3 and 40, while accessories for use at the cap end are selected by cylinder bore size.

**Rod and Cap End Accessories**

- Rod End** – rod clevis, eye bracket and pivot pin  
 – plain rod eye, clevis bracket and pivot pin  
 – rod eye with spherical bearing

- Cap End** – eye bracket for style BB mounting  
 (Note: pivot pin is supplied with cylinder)

**Rod End Fatigue**

Fatigue failure of the rod end is minimised by using a shouldered rod end, ie: Style 4, and tightening accessories securely against the rod shoulder. Where this is not the case, derating of the maximum working pressure may be required – please consult the factory.

**Rod Clevis, Eye Bracket and Pivot Pin**

Thread KK	Rod Clevis	Eye Bracket	Pivot Pin	Nominal Force kN	Mass kg
M10x1.5	50940G	69195	68368	18.3	0.7
M12x1.5	50941G	69195	68368	18.3	0.7
M20x1.5	50942G	96196	68369	46.8	2.3
M22x1.5	50943G	85361 <sup>1</sup>	68370	83.8	5.2
M26x1.5	50944G	85361 <sup>1</sup>	68370	91.0	5.1
M33x2	50945G	69198	68371	94.5	9.9
M39x2	50946G	85362 <sup>1</sup>	68372	203.3	19.5
M45x2	50947G	85363 <sup>1</sup>	68373	312.1	28.6
M48x2	50948G	85363 <sup>1</sup>	68373	312.1	28.5
M58x3	50949G	85364 <sup>1</sup>	68374	420.0	48.4
M64x2	50950G	85365 <sup>1</sup>	68375	420.0	54.9
M68x2	50951G	85365 <sup>1</sup>	68375	543.6	63.1
M76x2	50952G	73538	73545	256.0	104.8
M90x2	50953G	73539	73547	334.4	157.8
M100x2	50954G	73539	73547	334.4	156.6
M110x2	–	–	–	–	–

<sup>1</sup> Cylinder accessory dimensions conform to NFPA recommended standard, NFPA/T3.6.8.R1 - 1984

**Rod Eye with Spherical Bearing**

Thread KK	Part No.	Torque Load Nm	Mass kg
M16x1.5	145239	13	0.4
M20x1.5	145240	13	0.7
M27x2	145241	32	1.2
M33x2	145242	32	2.1
M42x2	145243	64	4.4
M48x2	145244	80	7.6
M64x3	145245	195	14.5

**Load Capacity**

The load capacities of the accessories shown on these pages is the recommended maximum load based on a 4:1 factor of safety in tension. (Pivot pin is rated in shear). Before specifying, compare the actual load or the pull force at maximum operating pressure of the cylinder with the load capacity of the accessory you plan to use. If the load or pull force of the cylinder exceeds the load capacity of the accessory, please consult the factory.

**Pivot Pin Diameters**

To obtain the same diameter of pivot pin at the rod end and cap end of a style BB clevis-mounted cylinder fitted with a rod clevis or plain rod eye, a no. 1 rod should be specified.

Pivot pins of the same diameter can be obtained at each end of a style SBa cylinder fitted with a rod end spherical bearing by specifying a style 7 rod end and nos. 2, 3 or 4 rods, as indicated in the table on page 3.

**Plain Rod Eye, Clevis Bracket and Pivot Pin**

Thread KK	Plain Rod Eye	Clevis Bracket	Pivot Pin	Nominal Force kN	Mass kg
M10x1.5	69089G	69205	68368	22.3	1.3
M12x1.5	69090G	69205	68368	25.4	1.3
M20x1.5	69091G	69206	68369	54.0	3.2
M22x1.5	69092G	69207	68370	58.0	6.6
M26x1.5	69093G	69207	68370	85.6	6.6
M33x2	69094G	69208	68371	149.4	12.7
M39x2	69095G	69209	68372	151.6	23.4
M45x2	69096G	69210	69215	147.2	41.1
M48x2	69097G	69210	69215	147.2	41.5
M58x2	69098G	69211	68374	155.6	51.2
M64x2	69099G	69212	68375	150.7	65.2
M68x2	69100G	69213	69216	164.6	69.5
M76x2	73536G	73542	73545	372.3	126.7
M90x2	73437G	73542	73545	372.3	124.0
M100x2	73438G	73543	82181	457.5	180.7
M110x2	73439G	73544	73547	483.4	173.5

**Cap End Eye Bracket for Style BB Cylinders**

Bore Ø	Eye Bracket Part No.	Nominal Force kN	Mass kg
38.1 (1½")	69195	18.3	0.4
50.8 (2")	69196	46.8	1.5
63.5 (2½")	69196	46.8	1.5
82.6 (3¼")	85361 <sup>1</sup>	91.0	3.4
101.6 (4")	69198	94.5	5.6
127.0 (5")	85362 <sup>1</sup>	220.6	11.1
152.4 (6")	85363 <sup>1</sup>	312.1	17.0
177.8 (7")	85364 <sup>1</sup>	420.0	27.4
203.2 (8")	85365 <sup>1</sup>	543.6	35.8
254.0 (10")	73538	256.0	55.6
304.8 (12")	73539	334.4	84.3

All dimensions are in millimetres unless otherwise stated.

**Rod Clevis, Eye Bracket and Pivot Pin**

**Rod Clevis Dimensions**

Part No.	A	CB	CD <sup>+0.10</sup> / <sub>+0.05</sub>	CE	CW	ER	KK	Nominal Force kN	Mass kg
50940G	19.1	19.8	12.70	38.1	12.7	12.7	M10x1.5	18.9	0.2
50941G	19.1	19.8	12.70	38.1	12.7	12.7	M12x1.5	21.9	0.2
50942G	28.6	32.6	19.05	54.0	15.9	19.1	M20x1.5	49.9	0.6
50943G	41.3	38.9	25.40	74.6	19.1	25.4	M22x1.5	83.8	1.3
50944G	41.3	38.9	25.40	74.6	19.1	25.4	M26x1.5	96.7	1.3
50945G	50.8	51.6	34.93	95.3	25.4	34.9	M33x2	149.4	3.1
50946G	57.2	64.7	44.45	114.3	31.8	44.5	M39x2	203.3	6.0
50947G	76.2	64.7	50.80	139.7	31.8	50.8	M45x2	317.9	8.4
50948G	76.2	64.7	50.80	139.7	31.8	50.8	M48x2	341.6	8.3
50949G	88.9	77.4	63.50	165.1	38.1	63.5	M58x2	480.2	15.1
50950G	88.9	77.4	76.20	171.5	38.1	69.9	M64x2	535.1	19.0
50951G	88.9	77.4	76.20	171.5	38.1	69.9	M68x2	589.9	18.7
50952G	88.9	102.8	88.90	196.9	50.8	88.9	M76x2	1048.8	34.1
50953G	101.6	116.0	101.60	223.8	57.2	101.6	M90x2	1292.2	49.8
50954G	101.6	116.0	101.60	223.8	57.2	101.6	M100x2	1480.0	48.6

**Rod Clevis (Female Clevis)**

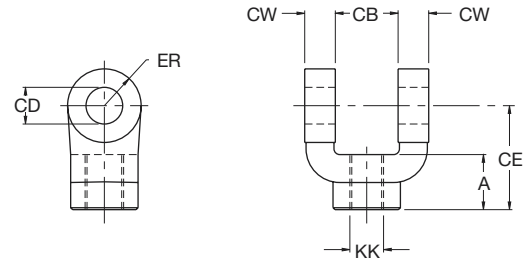

**Eye Bracket Dimensions**

Part No.	CB	CD <sup>+0.10</sup> / <sub>+0.05</sub>	DD	E	F	FL	LR	M	MR	R	Nominal Force kN	Mass kg
69195	19.1	12.70	10.3	63.5	9.5	28.6	19.1	12.7	14.3	41.4	18.3	0.4
69196	31.8	19.05	13.5	88.9	15.9	47.6	31.8	19.1	22.2	64.8	46.8	1.5
85361 <sup>1</sup>	38.1	25.40	16.7	114.3	22.2	60.3	38.1	25.4	31.8	82.6	91.0	3.4
69198	50.8	34.93	16.7	127.0	22.2	76.2	54.0	34.9	41.3	97.0	94.5	5.6
85362 <sup>1</sup>	63.5	44.45	23.0	165.1	28.6	85.7	57.2	44.5	54.0	125.7	220.6	11.1
85363 <sup>1</sup>	63.5	50.80	27.0	190.5	38.1	101.6	63.5	50.8	61.9	145.5	312.1	17.0
85364 <sup>1</sup>	76.2	63.50	30.2	215.9	44.5	120.6	76.2	63.5	76.2	167.1	420.0	27.4
85365 <sup>1</sup>	76.2	76.20	33.3	241.3	50.8	133.3	82.6	69.9	82.6	190.5	543.6	35.8
73538	101.6	88.90	46.0	320.7	42.9	144.5	101.6	88.9	95.3	244.3	256.0	55.6
73539	114.3	101.60	52.4	377.8	49.2	163.5	114.3	101.6	108.0	290.8	334.4	84.3

**Eye Bracket**

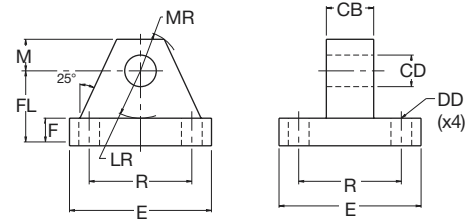

<sup>1</sup> Cylinder accessory dimensions conform to NFPA recommended standard, NFPA/T3.6.8.R1 - 1984

**Pivot Pin for Clevis Bracket & Eye Bracket**

Part No.	CD <sup>+0.00</sup> / <sub>-0.05</sub>	CL	G	Nominal Force kN	Mass kg
68368	12.73	45.8	56	38.4	0.1
68369	19.08	64.9	75	86.1	0.2
68370	25.43	77.4	88	152.9	0.5
68371	34.95	102.9	115	289.8	1.2
68372	44.48	128.3	143	469.1	2.4
68373	50.83	129.2	145	612.7	3.2
69215	50.83	140.9	158	612.7	3.5
68374	63.53	154.6	171	957.4	5.9
68375	76.23	154.2	173	1378.7	8.6
69216	76.23	167.2	185	1378.7	9.2
73545	88.93	205.2	225	1876.8	15.2
82181	101.63	219.8	254	2522.9	22.4
73547	101.63	231.2	266.7	2522.9	23.5

**Pivot Pin for Clevis Bracket & Eye Bracket**

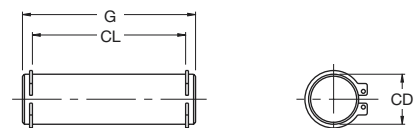

All dimensions are in millimetres unless otherwise stated.

**Plain Rod Eye, Clevis Bracket and Pivot Pin**

**Plain Rod Eye Dimensions**

Part No.	A min.	CA	CB	CD <sup>+0.10 +0.05</sup>	ER	KK	Nominal Force kN	Mass kg
69089G	19.1	38.1	19.1	12.70	18.3	M10x1.5	22.3	0.2
69090G	19.1	38.1	19.1	12.70	18.3	M12x1.5	25.4	0.2
69091G	28.6	52.4	31.8	19.05	27.0	M20x1.5	54.0	0.5
69092G	28.6	60.3	38.1	25.40	36.5	M22x1.5	58.0	1.1
69093G	41.3	71.4	38.1	25.40	36.5	M26x1.5	96.8	1.1
69094G	50.8	87.3	50.8	34.93	50.0	M33x2	149.4	2.6
69095G	57.2	101.6	63.5	44.45	63.5	M39x2	200.6	5.1
69096G	57.2	111.1	63.5	50.80	72.2	M45x2	238.6	6.4
69097G	76.2	127.0	63.5	50.80	72.2	M48x2	334.4	6.8
69098G	88.9	147.6	76.2	63.50	90.5	M58x2	440.1	12.1
69099G	88.9	155.6	76.2	76.20	108.0	M64x2	490.5	16.0
69100G	92.1	165.1	88.9	76.20	108.0	M68x2	549.8	19.6
73536G	101.6	193.7	101.6	88.90	126.2	M76x2	719.3	31.1
73437G	127.0	193.7	101.6	88.90	126.2	M90x2	969.0	28.4
73438G	139.7	231.8	114.3	101.60	144.5	M100x2	1220.9	42.5
73439G	139.7	231.8	127.0	101.60	144.5	M110x2	1375.6	48.4

**Plain Rod Eye**

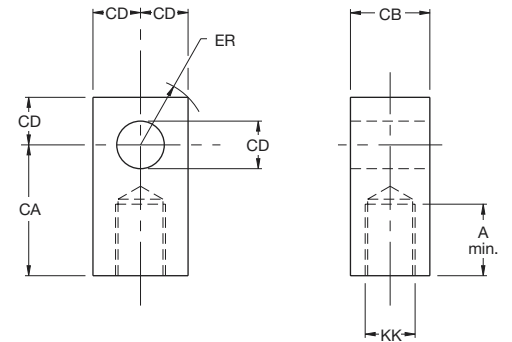

**Clevis Bracket Dimensions**

Part No.	CB	CD <sup>+0.10 +0.05</sup>	CW	DD	E	F	FL	LR	M	MR	R	Nominal Force kN	Mass kg
69205	19.8	12.70	12.7	10.3	88.9	12.7	38.1	19.1	12.7	15.9	64.8	32.6	1.0
69206	32.6	19.05	15.9	13.5	127.0	15.9	47.6	30.2	19.1	23.0	97.0	62.4	2.5
69207	38.9	25.40	19.1	16.7	165.1	19.1	57.2	38.1	25.4	31.8	125.7	85.6	5.0
69208	51.6	34.93	25.4	16.7	190.5	22.2	76.2	50.8	34.9	42.1	145.5	164.6	8.8
69209	64.7	44.45	31.8	23.0	241.3	22.2	92.1	69.9	44.5	56.4	190.5	151.6	15.9
69210	64.7	50.80	38.1	27.0	323.9	25.4	108.0	81.0	57.2	70.6	238.8	147.2	31.2
69211	77.4	63.50	38.1	30.2	323.9	25.4	114.3	88.9	63.5	79.4	238.8	155.6	33.2
69212	77.4	76.20	38.1	33.3	323.9	25.4	152.4	108.0	76.2	91.3	238.8	150.7	40.7
69213	90.1	76.20	38.1	33.3	323.9	25.4	152.4	108.0	76.2	91.3	238.8	164.6	40.7
73542	102.8	88.90	50.8	46.0	393.7	42.9	169.9	127.0	88.9	104.8	304.8	372.3	80.4
73543	116.0	101.60	50.8	52.4	444.5	49.2	195.3	146.1	101.6	123.8	349.3	457.5	115.8
73544	128.2	101.60	50.8	52.4	444.5	49.2	195.3	146.1	101.6	123.8	349.3	483.4	101.6

**Clevis Bracket**

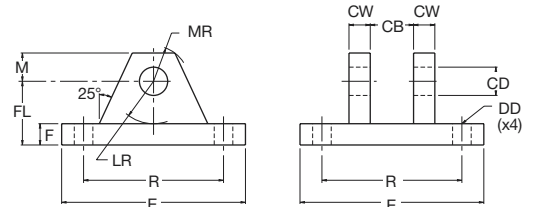

**Rod Eye with Spherical Bearing – ISO 6982**

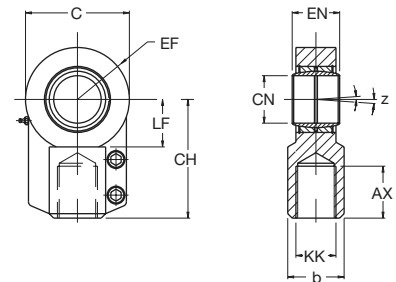

**Rod Eye with Spherical Bearing Dimensions – ISO 6982**

Part No.	AX min.	b	C max.	CH	CN H7	EF max.	EN h12	KK (Style 7)	LF	Z	Clamp screw torque (Nm)	Mass kg
145239	23	25	50	52	20	25	20	M16x1.5	22	4°	13	0.4
145240	29	30	62	65	25	32	25	M20x1.5	27		13	0.7
145241	37	38	76	80	32	40	32	M27x2	32		32	1.2
145242	46	47	97	97	40	50	40	M33x2	41		32	2.1
145243	57	58	118	120	50	63	50	M42x2	50		64	4.4
145244	64	70	142	140	63	71	63	M48x2	62		80	7.6
145245	86	90	180	180	80	90	80	M64x3	78		195	14.5

All dimensions are in millimetres unless otherwise stated.

### Mounting Styles

General guidance for the selection of mounting styles is given on page 9. The notes which follow provide information for use in specific applications.

### Mounting Bolts

Parker recommends that mounting bolts with a minimum strength of ISO 898/1 grade 10.9 should be used for fixing cylinders to the machine or base. This recommendation is of particular importance where bolts are placed in tension or subjected to shear forces. Mounting bolts should be torque loaded to their manufacturer's recommended figures.

### Tie Rod Nuts

Tie rod mounting nuts, with lubricated threads, should be to a minimum strength of ISO 898/2 grade 10, torque loaded to the figures shown.

Bore Ø	Tie Rod Nuts	
	Size A/F	Torque Nm min-max
38.1 (1½")	14.3	25-27
50.8 (2")	19.1	60-65
63.5 (2½")	19.1	60-65
82.6 (3¼")	23.8	160-165
101.6 (4")	23.8	175-180
127.0 (5")	33.4	420-425
152.4 (6")	38.1	715-735
177.8 (7")	42.9	1080-1100
203.2 (8")	47.6	1560-1580
254.0 (10")	-	3390-3410
304.8 (12")	-	715-735

### Extended Tie Rods

The standard tie rod extension for cylinders with mounting styles TB, TC and TD is shown as BB in dimension tables. Longer or shorter extensions can be supplied. Cylinders are supplied with an additional set of mounting nuts – see table.

Cylinders may be ordered with extended tie rods in addition to another mounting style. The extended tie rods may then be used for mounting other systems or machine components.

### Flange Mounted Cylinders

The diameter of the rod gland extension (B) at the head end can be used as a pilot to locate the cylinders in relation to the machine. After alignment has been obtained, the flanges may be drilled for pins or dowels to prevent movement.

### Pivot Mountings

Pivot pins are supplied with style BB cap fixed clevis mounted cylinders. Pivot pins are not supplied with the spherical bearing mounting, style SBa, as the pin length will be determined by the customer's equipment.

### Spherical Bearings

Where a spherical bearing mounting, style SBa, is specified for the cylinder, a rod eye with spherical bearing should be used at the rod end. The life of spherical bearings is influenced by factors such as specific load, direction of load, angle of oscillation, and type and frequency of lubrication. The maximum pressure rating for spherical bearing cylinders is 160 bar. If unusual operating conditions exist, please consult the factory.

### Trunnion Mounted Cylinders

Trunnions require lubricated pillow blocks with minimum bearing clearances. Blocks should be aligned and mounted to eliminate bending moments on the trunnion pins. Self-aligning mounts must not be used to support the trunnions as bending forces can be set up.

The position of an intermediate fixed trunnion is fixed during manufacture and its location must be specified at the time of order.

### Foot Mountings and Thrust Keys

The turning moment which results from the application of force by a foot mounted cylinder must be resisted by secure mounting and effective guidance of the load. A thrust key modification is recommended to provide positive cylinder location.

Thrust key mountings eliminate the need for fitted bolts or external keys on Styles C, F and G side mounted cylinders.

The gland retainer plate is extended below the nominal mounting surface to fit into a keyway milled into the mounting surface of the machine member. See 'Mounting Modifications' in the order code, page 41.

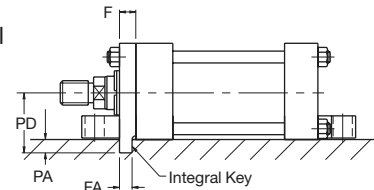

Bore Ø	F Nom.	FA +0.0 -0.075	PA +0.0 -0.2	PD
38.1 (1½")	9.5	8	4.9	36.5
50.8 (2")	15.9	14	8.0	46.0
63.5 (2½")	15.9	14	8.1	52.4
82.6 (3¼")	19.1	18	9.7	66.7
101.6 (4")	22.2	22	11.2	74.6
127.0 (5")	22.2	22	11.2	93.7
152.4 (6")	25.4	25	12.7	108.0
177.8 (7")	25.4	25	12.7	120.7
203.2 (8")	25.4	25	12.7	133.4

### Tie Rod Supports

To increase the resistance to buckling of long stroke cylinders, tie rod supports may be fitted. These move the tie rods radially outwards and allow longer than normal strokes to be used without the need for an additional mounting.

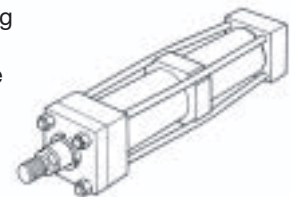

Bore Ø	Stroke (metres)												Number of supports req'd.
	0.9	1.2	1.5	1.8	2.1	2.4	2.7	3.0	3.3	3.6	3.9	4.2	
38.1	-	-	1	1	1	2	2	2	3	3	3	4	
50.8	-	-	-	1	1	1	1	2	2	2	2	3	
63.5	-	-	-	-	-	1	1	1	1	1	2	2	
82.6	-	-	-	-	-	-	-	1	1	1	1	1	
101.6	-	-	-	-	-	-	-	-	-	1	1	1	

Bore sizes above 101.6mm (4") do not require tie rod supports.

All dimensions are in millimetres unless otherwise stated.

**Stroke Tolerances**

Stroke length tolerances are required due to the build-up of tolerances of piston, head, cap and cylinder body. Standard production stroke tolerances are -0.4 to +0.8mm on all bore sizes and stroke lengths. For closer tolerances, please specify the required tolerance plus the operating temperature and pressure. Stroke tolerances of less than 0.4mm are generally impracticable due to the elasticity of cylinders and, in these cases, the use of a stroke limiter should be considered – see page 8.

**Manifold Ports**

Side mounted cylinders (Style C) can be supplied with the cylinder ports arranged for mounting and sealing to a manifold surface. The ports are drilled and counterbored for the O-ring seals provided. With these specifications, the mounting is designated Style CM. Please consult the factory.

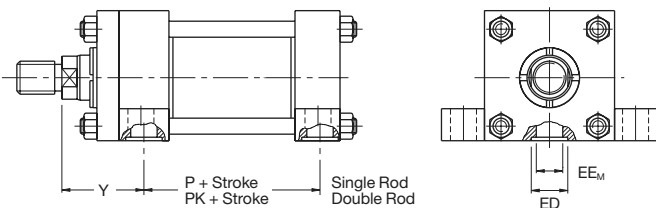

Bore Ø	Rod No.	Y ±0.8	P ±0.8	PK ±0.8	EE <sub>M</sub>	ED	Parker O-ring No.
38.1 (1½")	1	50.8	73.0	73.0	19.1	28.6	2-212
	2	60.3					
50.8 (2")	1	60.3	73.0	73.0	19.1	28.6	2-212
	2	66.7					
63.5 (2½")	1	60.3	76.2	76.2	19.1	28.6	2-212
	2	73.0					
	3	66.7					
82.6 (3¼")	1	69.9	88.9	88.9	25.4	34.9	2-216
	2	79.4					
	3	76.2					
101.6 (4")	1	72.2	101.6	103.2	25.4	34.9	2-216
	2	81.8					
	3	75.4					
127.0 (5")	1	79.4	108.0	108.0	25.4	34.9	2-216
	2	85.7					
	3	85.7					
	4	85.7					
152.4 (6")	All	88.9	130.2	123.8	31.8	41.3	2-220
177.8 (7")	All	96.8	149.2	136.5	38.1	47.6	2-223
203.2 (8")	All	100.0	168.3	155.6	38.1	47.6	2-223
254.0 (10")	1	120.7	215.9	215.9	50.8	60.3	010404-0224
	2	127.0					
304.8 (12")	1	136.5	257.2	257.2	63.5	73.0	010404-0256
	2	142.9					

**Calculation of Cylinder Diameter**

**Compression or 'Push' Applications**

If the piston rod is in compression, use the 'Push Force' table:

1. Identify the operating pressure closest to that required.
2. In the same column, identify the force required to move the load (always rounding up).
3. In the same row, look along to the cylinder bore required.

If the cylinder envelope dimensions are too large, increase the operating pressure, if possible, and repeat the exercise.

**Tension or 'Pull' Applications**

If the rod is in tension, use the 'Deduction for Pull Force' table:

1. Follow the procedure for 'push' applications above.
2. Using the 'Deduction for Pull Force' table, identify the force indicated according to the rod and pressure selected.
3. Deduct this from the original 'push' force. The resultant is the net force available to move the load.

If this force is not large enough, repeat the process with a higher system operating pressure or larger cylinder diameter.

**Push Force**

Bore Ø	Piston Area mm²	Cylinder Push Force in kN						Displacement per 10mm stroke Litres
		5 bar	10 bar	25 bar	70 bar	100 bar	210 bar	
38.1 (1½")	1140	0.6	1.1	2.9	8.0	11.4	24.0	0.0114
50.8 (2")	2020	1.0	2.0	5.0	14.1	20.2	42.5	0.0202
63.5 (2½")	3170	1.6	3.2	7.9	22.2	31.7	66.6	0.0317
82.6 (3¼")	5360	2.7	5.4	13.4	37.5	53.5	113	0.0535
101.6 (4")	8110	4.0	8.1	20.3	56.8	81.1	170	0.0811
127.0 (5")	12670	6.4	12.7	31.6	88.5	126	266	0.1267
152.4 (6")	18240	9.1	18.3	45.5	127	182	383	0.1827
177.8 (7")	24830	12.4	24.9	62.2	174	248	523	0.2486
203.2 (8")	32430	16.2	32.5	81.1	227	324	682	0.3246
254.0 (10")	50670	25.4	50.6	127	354	506	1065	0.5073
304.8 (12")	72970	36.5	73.0	182	510	730	1532	0.7294

**Deduction for Pull Force**

Piston Rod Ø	Piston Rod Area mm²	Piston Rod Force in kN						Displacement per 10mm stroke Litres
		5 bar	10 bar	25 bar	70 bar	100 bar	210 bar	
15.9 (5/8")	200	0.1	0.2	0.5	1.4	2.0	4.2	0.0020
25.4 (1")	500	0.3	0.5	1.3	3.5	5.0	10.5	0.0050
34.9 (1 3/8")	960	0.5	1.0	2.4	6.8	9.6	20.2	0.0097
44.5 (1 3/4")	1560	0.8	1.6	3.9	10.9	15.6	32.8	0.0156
50.8 (2")	2020	1.0	2.0	5.0	14.1	20.2	42.5	0.0202
63.5 (2 1/2")	3170	1.6	3.2	7.9	22.2	31.7	66.6	0.0317
76.2 (3")	4560	2.3	4.6	11.4	32.0	45.6	95.8	0.0456
88.9 (3 1/2")	6210	3.1	6.2	15.5	43.4	62.0	130	0.0621
101.6 (4")	8110	4.0	8.1	20.3	56.8	81.1	171	0.0811
127.0 (5")	12670	6.4	12.7	31.6	88.7	127	266	0.1267
139.7 (5 1/2")	15330	7.7	15.3	38.4	107	153	322	0.1523
177.8 (7")	24830	12.4	24.9	62.2	174	249	523	0.2486
215.8 (8 1/2")	36610	18.3	36.6	91.5	257	366	769	0.3663

All dimensions are in millimetres unless otherwise stated.

### Low Pressure Operation

At low operating pressures, a wide range of application factors such as seal friction and mounting alignment begin to affect cylinder performance. Low friction seals are available to special order, to optimise performance at low pressures. For information, please consult the factory.

### Maximum Pressure

The majority of Series 2H cylinders are suitable for pressures up to 210 bar for heavy-duty service with hydraulic oil. The 4:1 design factor rating shown is conservative for continuous severe applications. Safety factors at other pressures can be calculated from this rating. Mounting styles, stroke, etc., should be considered because of the limiting effect they may have on these ratings.

Three main areas of cylinder design may be affected by fatigue stress at lower pressures: the cylinder body (pressure envelope), the cylinder mountings, and the piston rod. The maximum pressures indicated in the tables are based on pure tensile and compressive loadings, without the presence of any bending stresses. Where it is impractical to avoid side loadings, eg: by the use of pivot mountings, please consult the factory.

### Cylinder Body (Pressure Envelope)

In many applications, the pressure developed within a cylinder may be greater than the working pressure, due to pressure intensification across the piston and cushioning, eg: in meter-out circuits. In most cases, this intensification does not affect the cylinder mountings or piston rod threads in the form of increased loading. This induced pressure should not exceed 320 bar. If in doubt, please consult the factory.

For pressure limitations of specific cylinders, please refer to the European cylinder InPHorm selection program HY07-1260/Eur.

### Maximum Pressure Ratings

Bore Ø (with rod no. 1)	4 : 1 Design Factor (yield)		Heavy-duty Service	
	(bar)	(psi)	(bar)	(psi)
38.1 (1½")	145	2040	210	3000
50.8 (2")	165	2340	210	3000
63.5 (2½")	135	1920	210	3000
82.6 (3¼")	150	2100	210	3000
101.6 (4")	145	1970	210	3000
127.0 (5")	135	1900	210	3000
152.4 (6")	150	2100	210	3000
177.8 (7")	130	1840	210	3000
203.2 (8")	145	1980	210	3000
254.0 (10")	155	2200	210	3000
304.8 (12")	170	2380	210	3000

### Maximum Pressure for H and J Mountings

Bore Ø	Style H Mounting <sup>1</sup> Pull applications (bar)					Style J Mounting <sup>2</sup> Push applications (bar)				
	Rod Numbers					Rod Numbers				
	1	2	3	4	5	1	2	3	4	5
38.1 (1½")	210	210	-	-	-	180	110	-	-	-
50.8 (2")	210	210	-	-	-	180	110	-	-	-
63.5 (2½")	210	210	210	-	-	180	110	130	-	-
82.6 (3¼")	210	210	210	-	-	180	110	145	-	-
101.6 (4")	210	210	210	-	-	180	110	125	-	-
127.0 (5")	150	210	180	195	-	160	60	115	85	-
152.4 (6")	150	210	180	195	-	130	60	100	75	-
177.8 (7")	110	150	120	125	-	110	40	90	70	-
203.2 (8")	110	150	120	-	130	70	40	55	-	45
254.0 (10")	180	210	-	-	-	72	46	-	-	-
304.8 (12")	135	210	-	-	-	Not recommended		-	-	-

<sup>1</sup> For pressures exceeding those shown use mounting HB or HH

<sup>2</sup> For pressures exceeding those shown use mounting JB or JJ

All dimensions are in millimetres unless otherwise stated.



**Piston Rod Size Selection**

For cylinders in compression (push) applications, the piston rod has to be of sufficient diameter to provide the necessary column strength. This is of particular importance in long stroke applications – see ‘Long Strokes and Stop Tubes’, page 34.

1. Determine the type of cylinder mounting style and rod end connection to be used. From the Stroke Factor table below, identify which factor corresponds to the application.
2. Using this stroke factor, determine the ‘basic length’ from the equation:

$$\text{Basic Length} = \text{Net Stroke} \times \text{Stroke Factor}$$

(The Piston Rod Selection Chart on page 34 is prepared for standard rod extensions beyond the face of the gland retainers. For rod extensions greater than standard, add the increases to the net stroke to obtain the ‘basic length’.)

3. Calculate the load imposed for the compression application

by multiplying the full bore area of the cylinder by the system pressure, or by referring to the Push and Pull Force charts on page 31.

4. Using the Piston Rod Selection Chart on page 34, look along the values of ‘basic length’ and force as found in 2 and 3 above, and note the point of intersection.

The correct piston rod diameter is read from the diagonally curved line **above** the point of intersection.

For cylinders in tensile (pull) applications, the rod size is selected by specifying standard cylinders with standard rod diameters and using them at or below the rated pressure.

**inPHorm**

For accurate sizing, please refer to the European cylinder inPHorm selection program HY07-1260/Eur.

**Stroke Factor Selection**

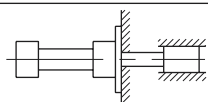
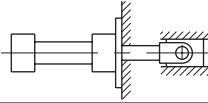
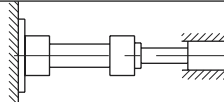
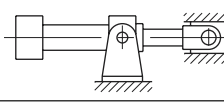
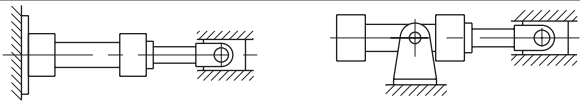
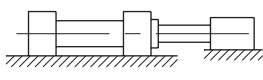
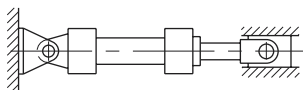
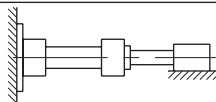
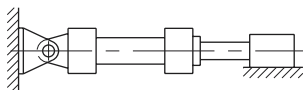
Rod End Connection	Mounting Style	Type of Mounting	Stroke Factor
Fixed and Rigidly Guided	TB, TD, J, JB, JJ, C, F, G		0.5
Pivoted and Rigidly Guided	TB, TD, J, JB, JJ, C, F, G		0.7
Fixed and Rigidly Guided	TC, H, HB, HH		1.0
Pivoted and Rigidly Guided	D		1.0
Pivoted and Rigidly Guided	TC, H, HB, HH, DD		1.5
Supported but not Rigidly Guided	TB, TD, J, JB, JJ, C, F, G		2.0
Pivoted and Rigidly Guided	BB, DB, SB		2.0
Supported but not Rigidly Guided	TC, H, HB, HH		4.0
Supported but not Rigidly Guided	BB, DB, SB		4.0

**Piston Rod Selection Chart**

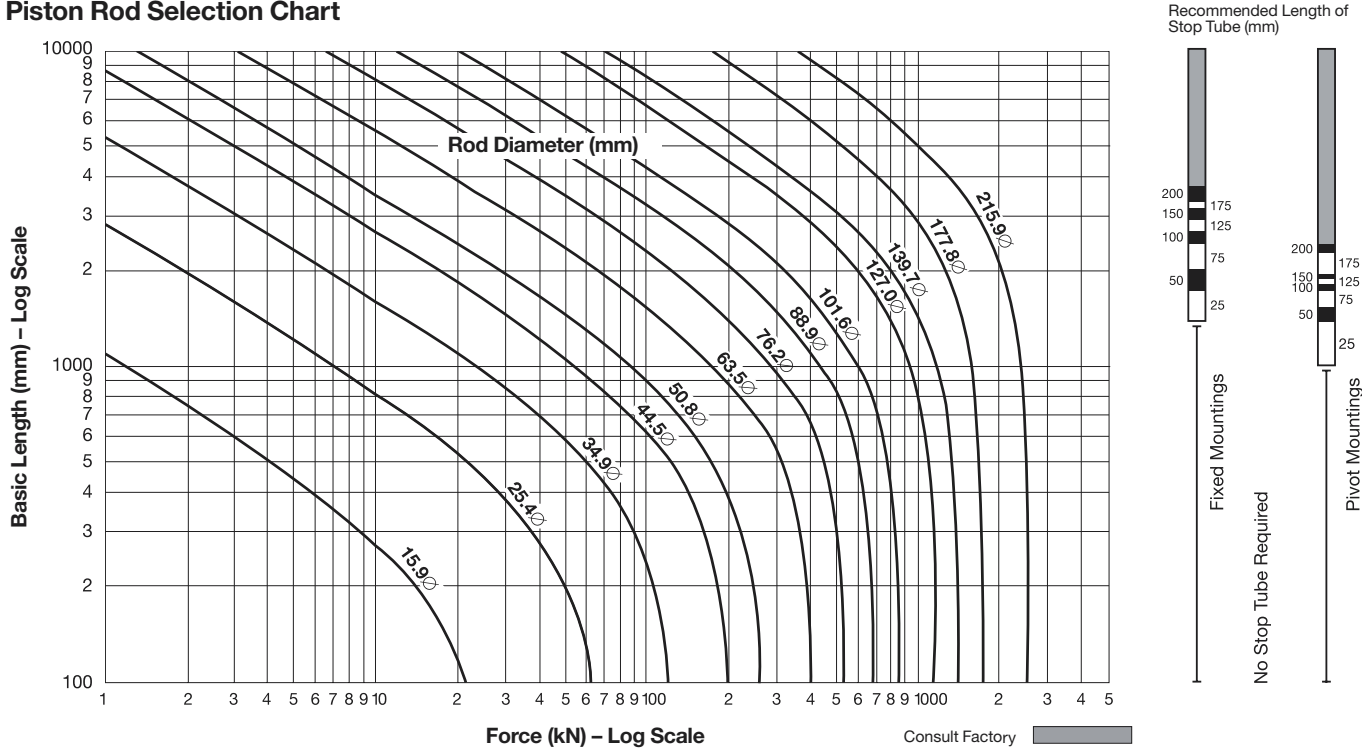

**Long Strokes and Stop Tubes**

For long stroke cylinders under compressive (push) loads, a stop tube should be used to reduce bearing stress. The required length of stop tube is read from the vertical columns on the right of the chart by following the horizontal band within which the point of intersection lies. Note that stop tube requirements differ for fixed and pivot mounted cylinders.

When specifying a cylinder with a stop tube, please insert an S (Special) and the net stroke of the cylinder in the order code and state the length of the stop tube. Note that net stroke is equal to the gross stroke of the cylinder less the length of the stop tube. The gross stroke determines the envelope dimensions of the cylinder.

If the required length of stop tube is in the region labelled 'consult factory', please submit the following information:

1. Cylinder mounting style.
2. Rod end connection and method of guiding load.
3. Bore required, stroke, length of rod extension (dimension W or WF - dimension V - see pages 3 and 40) if greater than standard.
4. Mounting position of cylinder. (Note if at an angle or vertical, and specify the direction of the piston rod.)
5. Operating pressure of cylinder, if limited to less than the standard pressure for the cylinder selected.

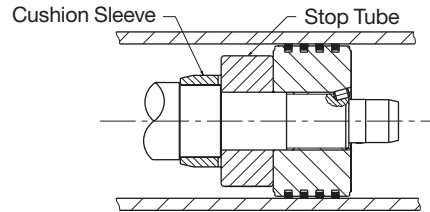

### Standard Ports

Series 2H cylinders are supplied as standard with BSPP ports to ISO 228/1, spot faced for sealing washers. Metric threaded ports to DIN 3852 Pt.1 and ISO 6149, or NPTF ports in sizes as shown for BSPP ports, can be supplied if required.

### Oversize Ports

For higher speed applications, oversize ports can be supplied in all bore sizes, but are not available on Style JJ mounting (please consult the factory). Ports one size larger than standard are the maximum that can be accommodated in most heads or caps within the standard envelope dimensions. Oversize or additional ports can be supplied on the sides of heads and caps that are not occupied by cushion valves. All oversize ports require welded port bosses, which protrude from the side of the cylinder.

Note that Y and P dimensions may vary slightly to accommodate oversize ports – please contact the factory where these dimensions are critical.

### Port Size and Piston Speed

The tables show piston speeds for standard and oversize ports and connecting lines where the velocity of the fluid is 5m/s. Due to piston rod displacement, the flow at the cap end port will be greater than that at the head end, at the same piston speed. If the desired piston speed results in a fluid flow in excess of 5m/s, larger lines with two ports per cap should be considered. For cylinders with oversize ports and with a fluid velocity exceeding 8m/s into the cap end, please consult the factory with details of the application. Parker recommends that a flow rate of 12m/s in connecting lines should not be exceeded.

Where large masses are involved, or piston speeds exceed 0.1m/s and the piston will make a full stroke, cushions are recommended – see page 36.

### Ports, Air Bleeds and Cushion Adjustment Location

The table below shows standard positions for ports, and cushion adjusting screws where fitted. Many mounting styles can be assembled with ports located at 90° or 180° from standard. In these cases, cushion needle and check valves, where fitted, are also repositioned since their relation with the port position does not change. Air bleeds, see page 8, may be fitted in unoccupied faces of the head or cap, depending on mounting.

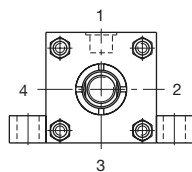

Bore Ø	Standard Ports				
	Port Size BSPP	Port size Metric	Tube Bore mm	l/min. flow at 5m/sec <sup>1</sup>	Piston Speed in m/sec
38.1 (1½")	G½	M22x1.5	13	40	0.58
50.8 (2")	G½	M22x1.5	13	40	0.33
63.5 (2½")	G½	M22x1.5	13	40	0.21
82.6 (3¼")	G¾	M27x2	15	53	0.17
101.6 (4")					0.11
127.0 (5")					0.07
152.4 (6")	G1	M33x2	19	85	0.08
177.8 (7")	G1¼	M42x2	24	136	0.09
203.2 (8")	G1½	M48x2	30	212	0.11
254.0 (10")	G2	M60x2	38	340	0.11
304.8 (12")	G2½	–	50	589	0.14

Bore Ø	Rod No	Oversize Ports				
		Port Size BSPP	Port size Metric	Tube Bore mm	l/min. flow at 5m/sec <sup>1</sup>	Piston Speed in m/sec
38.1 (1½")	1	G¾ <sup>2</sup> G¾ <sup>3</sup>	M27x2 <sup>3</sup>	15	53	0.78
	2					
50.8 (2")	1	G¾ <sup>2</sup> G¾ <sup>3</sup>	M27x2 <sup>3</sup>	15	53	0.44
	2					
63.5 (2½")	1	G¾	M27x2	15	53	0.28
82.6 (3¼")	2	G1	M33x2	19	85	0.27
101.6 (4")	All					0.18
127.0 (5")	All					0.11
152.4 (6")	All	G1¼	M42x2	24	136	0.12
177.8 (7")	All	G1½	M48x2	30	212	0.14
203.2 (8")	All	G2	–	38	340	0.18
254.0 (10")	All	–	–	–	–	–
304.8 (12")	All	–	–	–	–	–

<sup>1</sup> This refers to fluid velocity in connecting lines, not piston velocity  
<sup>2</sup> Supplied with welded port bosses at both head and cap  
<sup>3</sup> Supplied with welded port bosses at cap only

### Manifold Ports

Manifold ports are available on all mounting styles to special order. Side mounted cylinders (Style C) can be supplied with the cylinder ports arranged for mounting and sealing to a manifold surface – see page 31.

### Flange Ports

Flange ports are available on most large bore 2H series cylinders. Please consult the factory for details.

Positions of Ports and Cushion Screws in Head and Cap	
Head	Port Cushion
Cap	Port Cushion

Mounting Styles																																
TB, TC, TD, J, JB, H, HB, BB & SBa				JJ				HH				C		D		DB				DD				G & F								
1	2	3	4	1	2	3	4	1	2	3	4	1	1	3	1	2	3	4	1	2	3	4	1	2	3	4	1	2	3	4		
2	3	4	1	3	3	1	1	3	3	1	1	2	3	1	3	4	1	2	3	4	1	2	2	4	1	2	3	4	1	2	3	4
1	2	3	4	1	2	3	4	1	2	3	4	1	1	2	3	4	1	3	1	2	3	4	1	2	3	4	1	2	3	4		
2	3	4	1	3	4	1	2	3	3	1	1	2	3	4	1	2	3	1	3	4	1	2	2	4	1	2	3	4	1	2	3	4

All dimensions are in millimetres unless otherwise stated.

**An Introduction to Cushioning**

The option of cushioning is recommended as a means of controlling the deceleration of masses, or for applications where piston speeds are in excess of 0.1m/s and the piston will make a full stroke. Cushioning extends cylinder life and reduces undesirable noise and hydraulic shock. Cushions can be supplied at the head and/or cap ends of a cylinder without affecting its envelope or mounting dimensions.

**Standard Cushioning**

Where specified, 2H cylinders use cushions which are profiled to give efficient, progressive deceleration. Final speed may be adjusted using the cushion screws.

Note that cushion performance will be affected by the use of water or high water-based fluids. Please consult the factory for details.

**Alternative Forms of Cushioning**

Special designs can be produced to suit applications where the energy to be absorbed exceeds the standard cushion performance. Please consult the factory for further details.

**Cushion Length**

2H cylinders incorporate the longest cushion sleeve and spear that can be accommodated within the standard envelope without reducing the rod bearing and piston bearing lengths – see table of cushion lengths below.

**Cushion Calculations**

Modelling the cushion performance on uniform deceleration, the formulae below can be used to determine the approximate force developed in the cushion chamber when decelerating a load.

**Formulae**

$F = ma + A_d P/10 + mgsin\alpha - f$   
(for inclined or vertically downward direction of mass)

$F = ma + A_d P/10 - mgsin\alpha - f$   
(for inclined or vertically upward direction of mass)

Where:

- F = total force acting on the cushion chamber in Newtons
- m = mass of load in kilogrammes (including piston, rod, and rod end accessories, see table and pages 27 to 29)
- a = deceleration in m/s<sup>2</sup>, derived from the formula  $a = \frac{v^2}{2s \times 10^{-3}}$   
where: v = piston velocity in m/s  
s = cushion length in mm
- A<sub>d</sub> = piston area subjected to pressure, in mm<sup>2</sup> (see page 31)
- P = pump pressure in bar
- g = acceleration due to gravity = 9.81m/s<sup>2</sup>
- α = angle to the horizontal in degrees
- f = friction forces in Newtons = mg x 0.15

**Example**

The following example shows how to calculate horizontal deceleration (α=0).

Selected bore/rod 127/50.8mm (No. 1 rod)  
Pressure = 35 bar  
Mass = 2268kg  
Velocity = 0.6m/s  
Cushion length = 27mm  
Friction coefficient = 0.15 or 3337N

$F = ma + A_d P/10$

where  $a = \frac{0.6^2}{2 \times 27 \times 10^{-3}} = 6.66 \text{ m/s}^2$

and  $F = 2268 \times 6.66 + 12670 \times 35/10 - 3337 = 56128\text{N}$

The total deceleration force is developed by the fluid compressed in the cushion chamber. This pressure is approximately equal to the force divided by the annular area (cylinder bore area - rod area):

$\frac{56128\text{N}}{12670\text{mm}^2 - 2020\text{mm}^2} = 5.3\text{N/mm}^2 \text{ or } 53 \text{ bar.}$

This induced pressure should not exceed 320 bar.

**Cushion Length and Piston and Rod Mass**

Bore Ø	Rod No.	MM Rod Diameter	Cushion Length		Piston & Rod at Zero stroke kg	Rod only per 10mm Stroke kg		
			Head	Cap				
38.1 (1½")	1	15.9 (5/8")	28.6	30.2	0.45	0.02		
	2	25.4 (1")					0.73	0.04
50.8 (2")	1	25.4 (1")	28.6	28.6	0.97	0.04		
	2	34.9 (1¾")					1.49	0.07
63.5 (2½")	1	25.4 (1")	28.6	28.6	1.36	0.04		
	2	44.5 (1¾")					2.66	0.12
	3	34.9 (1¾")						
82.6 (3¼")	1	34.9 (1¾")	34.9	33.3	2.83	0.07		
	2	50.8 (2")	27.0		4.34	0.16		
	3	44.5 (1¾")	34.9		3.64	0.12		
101.6 (4")	1	44.5 (1¾")	34.9	31.8	4.99	0.12		
	2	63.5 (2½")	27.0		7.71	0.25		
	3	50.8 (2")	27.0		5.68	0.16		
127.0 (5")	1	50.8 (2")	27.0	28.6	8.73	0.16		
	2	88.9 (3½")			15.70	0.48		
	3	63.5 (2½")			10.75	0.25		
	4	76.2 (3")			13.19	0.35		
152.4 (6")	1	63.5 (2½")	33.3	38.1	14.98	0.25		
	2	101.6 (4")			23.88	0.63		
	3	76.2 (3")			17.49	0.35		
	4	88.9 (3½")			20.09	0.48		
177.8 (7")	1	76.2 (3")	46.0	49.2	22.28	0.35		
	2	127.0 (5")	42.9		39.59	0.98		
	3	88.9 (3½")	46.0		25.03	0.48		
	4	101.6 (4")	33.3		29.01	0.63		
203.2 (8")	1	88.9 (3½")	52.4	50.8	33.04	0.48		
	2	139.7 (5½")	49.2		54.78	1.19		
	3	101.6 (4")	33.3		37.11	0.63		
	4	127.0 (5")	42.9		47.91	0.98		
	5	127.0 (5")	42.9		47.91	0.98		
254.0 (10")	1	127.0 (5")	54.0	50.8	76.38	0.98		
	2	177.8 (7")			105.39	1.92		
304.8 (12")	1	139.7 (5½")	54.0	50.8	120.47	1.19		
	2	215.9 (8½")			177.25	2.84		

All dimensions are in millimetres unless otherwise stated.

Fluid Group	Seal Materials – a combination of:	Fluid Medium to ISO 6743/4-1982	Temperature Range
1	Nitrile (NBR), PTFE, enhanced polyurethane (AU)	Mineral Oil HH, HL, HLP, HLP-D, HM, MIL-H-5606 oil, air, nitrogen	-20°C to +80°C
2	Nitrile (NBR), PTFE	Water glycol (HFC)	-20°C to +60°C
5	Fluorocarbon elastomer (FPM), PTFE	Fire resistant fluids based on phosphate esters (HFD-R) Also suitable for hydraulic oil at high temperatures or in hot environments. <b>Not suitable for use with Skydrol.</b> See fluid manufacturer's recommendations.	-15°C to +150°C
6	Various compounds including nitrile, polyamide, enhanced polyurethane, fluorocarbon elastomers and PTFE	Water	+5°C to +50°C
7		Oil in water emulsion 95/5 (HFA)	+5°C to +50°C
		Water in oil emulsion 60/40 (HFB)	+5°C to +50°C

### Operating Medium

The table above is a guide to the sealing compounds and operating parameters of the materials used for rod gland, piston and body seals. If there is doubt regarding seal compatibility with the operating medium, please consult the factory.

#### Notes

**Group 1 Seals** are manufactured from an enhanced polyurethane and do not require a gland seal back-up washer. They should not be used if the working fluid is water glycol.

**Group 6 Seals** – System pressure should not exceed 70 bar when using HFA fluids.

### Temperature

Where operating conditions fall outside those specified in the table, please contact the factory.

### Green Fluids

Seals for use with specific 'green fluids' are available to special order. Please consult the factory for details.

### External Fluids

The environment in which a cylinder is used may cause fluids such as cutting fluids, coolants, and wash down fluids, to come into contact with the external surfaces of the cylinder. These fluids may attack the seals, and must be taken into account when selecting and specifying seal compounds.

### Special Seal Designs and Materials

In addition to the standard and optional seals shown in the table, special seals can also be supplied – please consult the factory with details of the application. Please insert an S (Special) in the order code and specify fluid medium when ordering.

### Low Friction Seals

For applications where very low friction and an absence of stick-slip are important, the option of low friction seals is available. In low pressure applications, their use should also be considered. If in doubt, please consult the factory. The gland seals comprise two low friction PTFE stepped seals and a conventional double lip wiper.

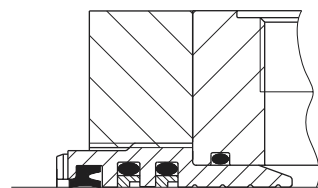

### Water Service

Modifications for use with water as the fluid medium include a stainless steel piston rod with lipseal piston, and plating of internal surfaces. When ordering, please specify the maximum operating pressure or load/speed conditions, as the stainless steel rod is of lower tensile strength than the standard material.

### Warranty

Parker Hannifin warrants cylinders modified for water or high water content fluid service to be free of defects in materials or workmanship, but cannot accept responsibility for premature failure caused by excessive wear resulting from lack of lubricity, or where failure is caused by corrosion, electrolysis or mineral deposits within the cylinder.

### Filtration

For maximum component life, the system should be protected from contamination by effective filtration. Fluid cleanliness should be in accordance with ISO 4406. The quality of filtration should be in accordance with the appropriate ISO standards.

The rating of the filter medium depends on the system components and the application. The minimum required for hydraulic systems should be class 19/15 to ISO 4406, which equates to 24µ(β10≥75) to ISO 4572.

**Service Assemblies and Seal Kits**

When ordering Service Assemblies and Seal Kits, please refer to the identification plate on the cylinder body, and supply the following information:

**Serial Number - Bore - Stroke - Model Number - Fluid Type**

**Key to Part Numbers**

- 1 Head
- 7 Cap
- 14 Gland/bearing cartridge
- 15 Cylinder body
- 17 Piston
- 18 Cushion sleeve
- 19 Tie rod
- 23 Tie rod nut
- 26 Back-up washer – only on 177.8mm to 304.8mm (7" to 12") bore cylinders
- 27 Retainer
- 34 Piston rod – single rod, no cushion

- 61<sup>1</sup> Piston rod – double (weaker<sup>2</sup>) rod, cushion one end
- 69 O-ring – needle valve and check valve screws
- 69a O-ring – cartridge-type needle valve
- 70 Needle valve, cushion adjustment – bore sizes above 63.5mm (2<sup>1</sup>/<sub>2</sub>" )
- 70a Needle valve assembly, cartridge type – bore sizes up to 63.5mm (2<sup>1</sup>/<sub>2</sub>" )
- 71 Ball – cushion check valve – bore sizes above 101.6mm (4")
- 72 Cushion check valve screw – bore sizes above 101.6mm (4")
- 73 Floating cushion bush
- 74 Retaining ring for cushion bush
- 119 PTFE rings (Hi-Load piston)
- 120 Rubber pre-load rings (Hi-Load piston)
- 121 Wear rings (Hi-Load piston)

<sup>1</sup> Not illustrated

<sup>2</sup> See page 26 – double rod strength

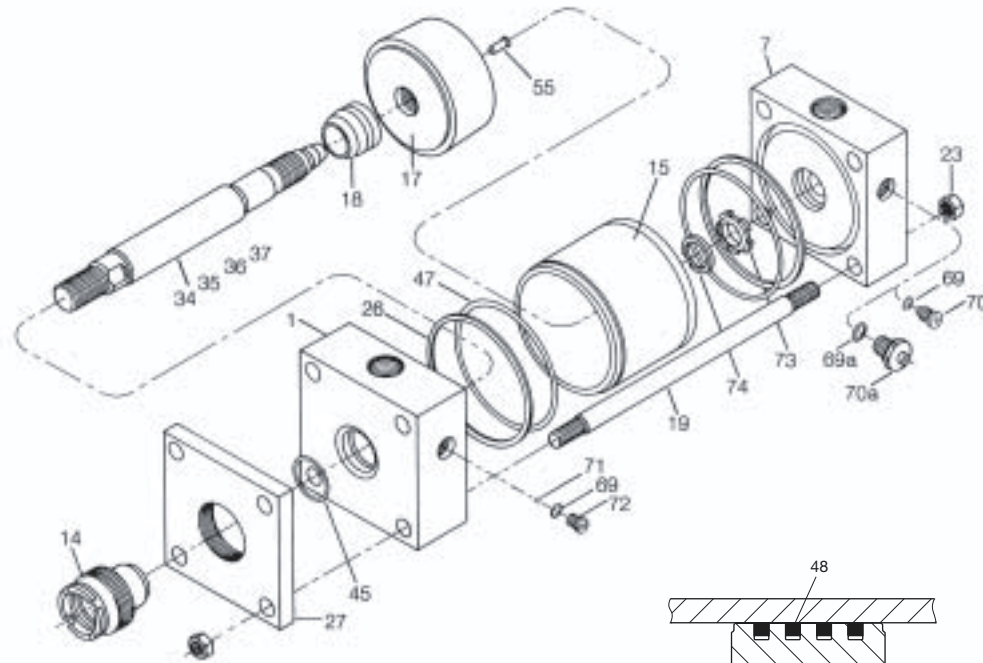

Piston Rod Ø	Gland Cartridge Wrench	Spanner Wrench
15.9	69590	11676
25.4	69591	11676
34.9	69592	11703
44.5	69593	11677
50.8	69594	11677
63.5	69595	11677
76.2	69596	11677
88.9	69597	11677
101.6	69598	11677
127.0	69599	11678
139.7	69600	11678
177.8	-	-
215.9	-	-

- 35 Piston rod – single rod, cushion at head end
- 36 Piston rod – single rod, cushion at cap end
- 37 Piston rod – single rod, cushion at both ends
- 40 Wiperseal – for gland
- 41 Lipseal – for gland
- 42 Lipseal – for Lipseal piston
- 43 Back-up washer – for gland lipseal 41 (Groups 2, 5, 6 & 7 seals)
- 44 Back-up washer – for Lipseal piston
- 45 O-ring – gland/head
- 47 O-ring – cylinder body
- 48 Cast iron piston ring
- 55 Locking pin – piston/rod
- 57<sup>1</sup> Piston rod – double (stronger<sup>2</sup>) rod, no cushion
- 58<sup>1</sup> Piston rod – double (stronger<sup>2</sup>) rod, cushion one end
- 60<sup>1</sup> Piston rod – double (weaker<sup>2</sup>) rod, no cushion

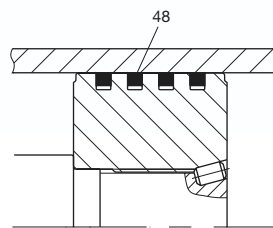

**Cast Iron Piston**

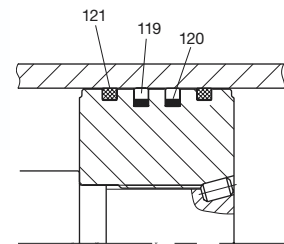

**Hi-Load Piston**

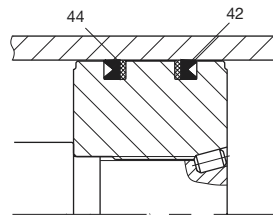

**Lipseal Piston**

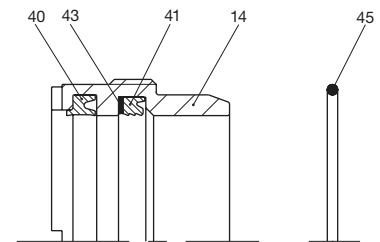

**Gland Cartridge and Seals**

**Piston and Gland Service Kits**

(see key to part numbers opposite)

**Gland Service Cartridge Kit** Contain items 14, 40, 41, 43, 45. Where the original gland incorporates a gland drain, please consult the factory.

**Gland Service Kit** Contain items 40, 41, 43, 45.

Piston Rod Ø	Gland Service Cartridge Kit * Standard Seals	Gland Service Kit * Standard Seals
15.9 (5/8")	RG2HLTS061	RK2HLTS061
25.4 (1")	RG2HLTS101	RK2HLTS101
34.9 (1 3/8")	RG2HLTS131	RK2HLTS131
44.5 (1 3/4")	RG2HLTS171	RK2HLTS171
50.8 (2")	RG2HLTS201	RK2HLTS201
63.5 (2 1/2")	RG2HLTS251	RK2HLTS251
76.2 (3")	RG2HLTS301	RK2HLTS301
88.9 (3 3/2")	RG2HLTS351	RK2HLTS351
101.6 (4")	RG2HLTS401	RK2HLTS401
127.0 (5")	RG2HLTS501	RK2HLTS501
139.7 (5 1/2")	RG2HLTS551	RK2HLTS551
127.0 (5") <sup>1</sup>	RG902HTS501	RK902HTS501
139.7 (5 1/2") <sup>2</sup>	RG922HTS551	RK922HTS551
177.8 (7") <sup>1</sup>	RG902HLF701	RK902HLF701
215.8 (8 1/2") <sup>2</sup>	RG922HLF851	RK922HLF851

<sup>1</sup> 254.0mm (10") bore size only    <sup>2</sup> 304.8 mm (12") bore size only

**Piston Service Kit, Cast Iron Rings** Contains two each of items 26 (where fitted) and 47, plus four of item 48.

**Piston Service Kit, Lipseal Piston** Contains two each of items 26 (where fitted), 42, 44 and 47.

**Piston Service Kit, Hi-Load Piston** Contains two each of items 26 (where fitted), 47, 119, 120 and 121.

Bore Ø	Piston Service Kit Cast Iron Rings	Piston Service Kit * Lipseal Piston	Piston Service Kit * Hi-Load Piston
38.1 (1 1/2")	PR152H001	PK152HLL01	PK152HK001
50.8 (2")	PR202H001	PK202HLL01	PK202HK001
63.5 (2 1/2")	PR252H001	PK252HLL01	PK252HK001
82.6 (3 1/4")	PR322H001	PK322HLL01	PK322HK001
101.6 (4")	PR402H001	PK402HLL01	PK402HK001
127.0 (5")	PR502H001	PK502HLL01	PK502HK001
152.4 (6")	PR602H001	PK602HLL01	PK602HK001
177.8 (7")	PR702H001	PK702HLL01	PK702HK001
203.2 (8")	PR802H001	PK802HLL01	PK802HK001
254.0 (10")	PR902H001	PK902HLL01	PK902HK001
304.8 (12")	PR922H001	PK922HLL01	PK922HK001

**\* Seal Groups – Ordering**

The kit numbers shown above are for Group 1 seals. For Group 2, 5, 6 or 7 gland seals, substitute 'AHL' for 'HLTS' where used, and replace the '1' at the end of the number sequence with '2', '5', '6' or '7'. For example, a Group 5 Gland Service Cartridge Kit for a 50.8mm rod will be RG2AHL205. For Group 2, 5, 6 or 7 piston seals, substitute a '2', '5', '6' or '7' for the '1' at the end of the number sequence.

All dimensions are in millimetres unless otherwise stated.

**Contents of Service Assembly Kits**

(see key to part numbers opposite)

**Head Assembly**

Non-cushioned: 1, 26, 47  
Cushioned: 1, 26, 47, 69, (69a), 70, (70a)

**Cap Assembly**

Non-cushioned: 7, 26, 47  
Cushioned: 7, 26, 47, 69, (69a), 70, (70a), 73, 74

**Cylinder Body**

All types: 15

**Cushion Screw/Cartridge Assembly**

Screw type: 69, 70  
Cartridge type: 69a, 70a

**Check Valve Screw Assembly**

Screw type: 69, 71, 72 (bore sizes above 101.6mm)

**Piston Rod Assemblies**

These kits contain a fully assembled piston and rod assembly and are available with the following piston and rod types:

**Piston Types**

Cast Iron Ring: 17, 48  
Lipseal: 17, 42, 44  
Hi-Load: 17, 119, 120, 121

**Rod Types**

Single rod, non-cushioned: 34  
Single rod, cushioned head: 35, 18  
Single rod, cushioned cap: 36  
Single rod, cushioned both ends: 37, 18  
  
Double rod, non-cushioned: 57, 60,  
Double rod, cushioned stronger end: 58, 60, 18  
Double rod, cushioned weaker end: 58, 61, 18  
Double rod, cushioned both ends: 58, 61, 18 x 2

**Tie Rod Torques**

Please refer to the table on page 30.

**Repairs**

Although 2H cylinders are designed to make on-site maintenance or repairs as easy as possible, some operations can only be carried out in our factory. It is standard policy to fit a cylinder returned to the factory for repair with those replacement parts which are necessary to return it to 'as good as new' condition. Should the condition of the returned cylinder be such that repair would be uneconomical, you will be notified.

**254.0mm & 304.8mm (10" & 12") Bores Only**

**Rod End Details – All Except J, JB and JJ Mountings**

**Rod End Style 4**

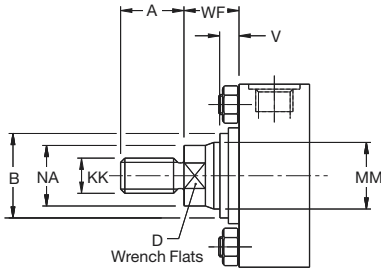

**Rod End Style 8**

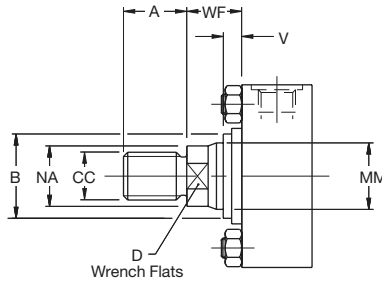

**Rod End Style 9**

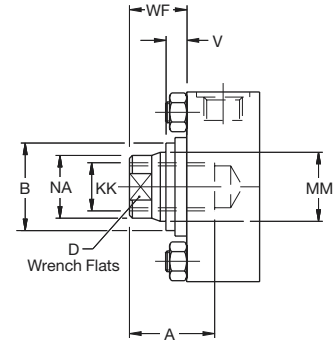

**Rod End Details – J and JB Mountings**

**Rod End Style 4**

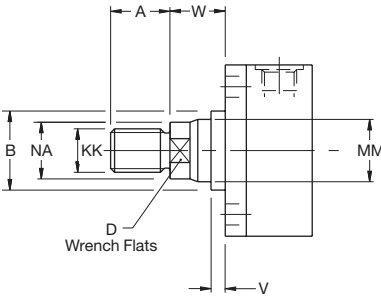

**Rod End Style 8**

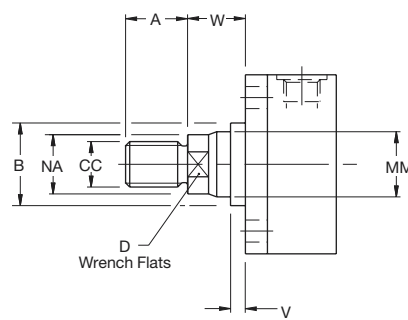

**Rod End Style 9**

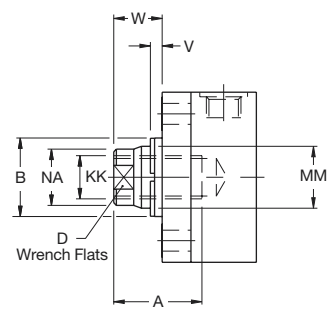

**Rod End Details – JJ Mounting**

**Rod End Style 4**

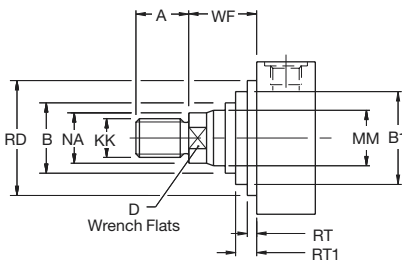

**Rod End Styles 4 & 8**

Style 4 rod ends are recommended for all applications in which the work piece is secured against the rod shoulder. Where the work piece is not shouldered, Style 8 rod ends are recommended. If rod end style is not specified, Style 4 will be supplied.

**Rod End Style 9**

For applications where a female thread is required.

**Rod End Style 3**

Non-standard piston rod ends are designated 'Style 3'. A dimensional sketch or description should accompany the order. Please specify dimensions KK or CC, and A.

**Rod End Dimensions – 254.0mm & 304.2mm (10" & 12") Bore Sizes Only**

Bore Ø	Rod No.	MM Rod Diameter	Style 4 & 9		Style 8		A	B +0.00 -0.13	D	NA	V	W	WF	JJ Mount Only			
			KK Metric	KK UNF	CC Metric	CC UNF								B1	RD max.	RT	RT1
254.0 (10")	1	127.0 (5")	M90x2	3½ - 12	M110x2	4¾ - 12	127	146.0	110	123.8	7	32	74.9	-	241.3	25.4	-
	2	177.8 (7")	M100x2	4 - 12	M130x2	4¾ - 12	127	196.8	150	174.6	13	38	81.0	214.3	273.1	28.6	41.7
304.8 (12")	1	139.7 (5½")	M100x2	4 - 12	M130x2	5¼ - 12	140	158.7	120	136.5	7	32	82.0	-	206.4	33.3	-
	2	215.9 (8½")	M115x2	4½ - 12	M130x2	5¼ - 12	140	234.9	180	212.7	13	38	87.2	260.3	336.6	28.6	46.1

All dimensions are in millimetres unless otherwise stated.



How To Order

2H Series

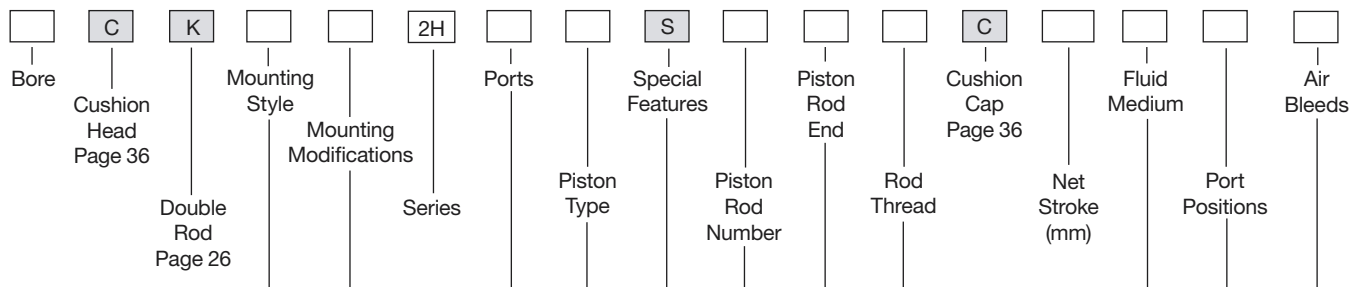

Code	Special Features	Page
S	Flange Ports	35
S	Oversize Ports	35
S	Special Seals	37
S	Stop Tube	34
S	Stroke Limiter	8
S	Rod End Bellows	8
S	Gland Drain Port	8
S	Tie Rod Supports	30
S	Water Service Modifications	37
- or to customer specification		

Code	Piston	Page
C	Cast iron rings (standard)	6
K	Hi-Load	6
L	Lipseal	6

Code	Port Style	Page
R	BSPP (ISO 228) – standard	35
G	Metric (ISO 3852 Pt.1)	35
U	NPTF (dry seal pipe thread)	35
Y	Metric (ISO 6149)	35

Code	Modification	Page
P	Thrust Key (Styles C, F, G only)	30
M	Manifold Port O-ring (Style C only)	31

Code	Mounting Style	Page
TB, TC, TD	Extended Tie Rods	10, 11
J, JJ, JB	Head Flanges	12, 13, 22
H, HH, HB	Cap Flanges	14, 15, 23
C	Side Lugs	16, 25
F	Side Tapped Holes	16
G	Side End Lugs	17
BB	Cap Fixed Clevis	18, 25
SBa	Cap Fixed Eye with Spherical Bearing	18
D, DB, DD	Fixed Trunnions	20, 21, 24

Code	Fluid Medium	Page
M	Group 1	37
C	Group 2	37
D	Group 5	37
A1	Group 6	37
B	Group 7	37

Code	Port Position	Page
eg: 1	Head position 1-4	35
1	Cap position 1-4	35

Code	Air Bleed Position	Page
eg: 4	Head position 1-4	8, 35
4	Cap position 1-4	8, 35
00	No air bleeds	8, 35

Code	Thread	Page
M	Metric (standard)	3, 40
A	UNF	

Code	Rod End Style	Page
4	Style 4	3, 40
7	Style 7	3, 40
8	Style 8	3, 40
9	Style 9	3, 40
3	Style 3 (Special) – please supply description or drawing	3, 40

Code	Rod Number	Page
1	Rod No. 1	3, 40
2	Rod No. 2	3, 40
3	Rod No. 3	3, 40
4	Rod No. 4	3, 40
5	Rod No. 5	3, 40

**Accessories**

Please state on order whether accessories are to be fitted to the cylinder or supplied separately.

**Key**

All selections   
 Indicate optional features or leave blank

**Double Rod Cylinders – Example**

100	K	JJ	2H	R	K	1	4	M	1	4	M	125	D	11	44
-----	---	----	----	---	---	---	---	---	---	---	---	-----	---	----	----



# Parker Worldwide

**AE – UAE, Dubai**  
Tel: +971 4 8127100  
parker.me@parker.com

**AR – Argentina, Buenos Aires**  
Tel: +54 3327 44 4129

**AT – Austria, Wiener Neustadt**  
Tel: +43 (0)2622 23501-0  
parker.austria@parker.com

**AT – Eastern Europe, Wiener Neustadt**  
Tel: +43 (0)2622 23501 900  
parker.easteurope@parker.com

**AU – Australia, Castle Hill**  
Tel: +61 (0)2-9634 7777

**AZ – Azerbaijan, Baku**  
Tel: +994 50 2233 458  
parker.azerbaijan@parker.com

**BE/LU – Belgium, Nivelles**  
Tel: +32 (0)67 280 900  
parker.belgium@parker.com

**BR – Brazil, Cachoeirinha RS**  
Tel: +55 51 3470 9144

**BY – Belarus, Minsk**  
Tel: +375 17 209 9399  
parker.belarus@parker.com

**CA – Canada, Milton, Ontario**  
Tel: +1 905 693 3000

**CH – Switzerland, Etoy**  
Tel: +41 (0) 21 821 02 30  
parker.switzerland@parker.com

**CL – Chile, Santiago**  
Tel: +56 2 623 1216

**CN – China, Shanghai**  
Tel: +86 21 2899 5000

**CZ – Czech Republic, Klecany**  
Tel: +420 284 083 111  
parker.czechrepublic@parker.com

**DE – Germany, Kaarst**  
Tel: +49 (0)2131 4016 0  
parker.germany@parker.com

**DK – Denmark, Ballerup**  
Tel: +45 43 56 04 00  
parker.denmark@parker.com

**ES – Spain, Madrid**  
Tel: +34 902 330 001  
parker.spain@parker.com

**FI – Finland, Vantaa**  
Tel: +358 (0)20 753 2500  
parker.finland@parker.com

**FR – France, Contamine s/Arve**  
Tel: +33 (0)4 50 25 80 25  
parker.france@parker.com

**GR – Greece, Athens**  
Tel: +30 210 933 6450  
parker.greece@parker.com

**HK – Hong Kong**  
Tel: +852 2428 8008

**HU – Hungary, Budapest**  
Tel: +36 1 220 4155  
parker.hungary@parker.com

**IE – Ireland, Dublin**  
Tel: +353 (0)1 466 6370  
parker.ireland@parker.com

**IN – India, Mumbai**  
Tel: +91 22 6513 7081-85

**IT – Italy, Corsico (MI)**  
Tel: +39 02 45 19 21  
parker.italy@parker.com

**JP – Japan, Fujisawa**  
Tel: +(81) 4 6635 3050

**KR – South Korea, Seoul**  
Tel: +82 2 559 0400

**KZ – Kazakhstan, Almaty**  
Tel: +7 7272 505 800  
parker.easteurope@parker.com

**LV – Latvia, Riga**  
Tel: +371 6 745 2601  
parker.latvia@parker.com

**MX – Mexico, Apodaca**  
Tel: +52 81 8156 6000

**MY – Malaysia, Shah Alam**  
Tel: +60 3 7849 0800

**NL – The Netherlands, Oldenzaal**  
Tel: +31 (0)541 585 000  
parker.nl@parker.com

**NO – Norway, Ski**  
Tel: +47 64 91 10 00  
parker.norway@parker.com

**NZ – New Zealand, Mt Wellington**  
Tel: +64 9 574 1744

**PL – Poland, Warsaw**  
Tel: +48 (0)22 573 24 00  
parker.poland@parker.com

**PT – Portugal, Leca da Palmeira**  
Tel: +351 22 999 7360  
parker.portugal@parker.com

**RO – Romania, Bucharest**  
Tel: +40 21 252 1382  
parker.romania@parker.com

**RU – Russia, Moscow**  
Tel: +7 495 645-2156  
parker.russia@parker.com

**SE – Sweden, Spånga**  
Tel: +46 (0)8 59 79 50 00  
parker.sweden@parker.com

**SG – Singapore**  
Tel: +65 6887 6300

**SK – Slovakia, Banská Bystrica**  
Tel: +421 484 162 252  
parker.slovakia@parker.com

**SL – Slovenia, Novo Mesto**  
Tel: +386 7 337 6650  
parker.slovenia@parker.com

**TH – Thailand, Bangkok**  
Tel: +662 717 8140

**TR – Turkey, Istanbul**  
Tel: +90 216 4997081  
parker.turkey@parker.com

**TW – Taiwan, Taipei**  
Tel: +886 2 2298 8987

**UA – Ukraine, Kiev**  
Tel +380 44 494 2731  
parker.ukraine@parker.com

**UK – United Kingdom, Warwick**  
Tel: +44 (0)1926 317 878  
parker.uk@parker.com

**US – USA, Cleveland (industrial)**  
Tel: +1 216 896 3000

**US – USA, Lincolnshire (mobile)**  
Tel: +1 847 821 1500

**VE – Venezuela, Caracas**  
Tel: +58 212 238 5422

**ZA – South Africa, Kempton Park**  
Tel: +27 (0)11 961 0700  
parker.southafrica@parker.com

## European Product Information Centre

Free phone: 00 800 27 27 5374  
(from AT, BE, CH, CZ, DE, DK, EE, ES, FI, FR, IE, IL, IS, IT, LU, MT, NL, NO, PL, PT, RU, SE, UK, ZA)  
Fax: +44 1442 458112

## US Product Information Centre

Free phone: 1-800-27 27 537  
www.parker.com

